

Article

Transmission Delay-Based Uplink Multi-User Scheduling in IEEE 802.11ax Networks [†]

Yonggang Kim ¹, Gyungmin Kim ², Youngwoo Oh ³ and Wooyeol Choi ^{3,*}¹ Samsung Electronics, Suwon 16677, Korea; yonggang.kim@samsung.com² School of Electrical Engineering and Computer Science, Gwangju Institute of Science and Technology (GIST), Gwangju 61005, Korea; gyungminkim@gist.ac.kr³ Department of Computer Engineering, Chosun University, Gwangju 61452, Korea; duddn1022@chosun.kr

* Correspondence: wyc@chosun.ac.kr; Tel.: +82-62-230-6033

[†] This paper is an extended version of our paper published in IEEE International Conference on Consumer Electronics (ICCE), Las Vegas, NV, USA, 4–6 January 2020.

Abstract: As the demands for uplink traffic increase, improving the uplink throughput has attracted research attention in IEEE 802.11 networks. To avoid excessive competition among stations and enhance the uplink throughput performance, the IEEE 802.11ax standard supports uplink multi-user transmission scenarios, in which AP triggers certain stations in a network to transmit uplink data simultaneously. The performance of uplink multi-user transmissions highly depends on the scheduler, and station scheduling is still an open research area in IEEE-802.11ax-based networks. In this paper, we propose a transmission delay-based uplink multi-user scheduling method. The proposed method consists of two steps. In the first step, the proposed method makes station clusters so that stations in each cluster have similar expected transmission delays. The transmission delay-based station clustering increases the use of uplink data channels during the uplink multi-user transmission scenario specified in IEEE 802.11ax. In the second step, the proposed method selects cluster for uplink multi-user transmissions. The cluster selection can be performed with a proportional fair-based approach. With the highly channel-efficient station cluster, the proposed scheduling method increases network throughput performance. Through the IEEE 802.11ax standard compliant simulations, we verify the network throughput performance of the proposed uplink scheduling method.

Keywords: IEEE 802.11ax; uplink multi-user scheduling; transmission delay-based clusteringcheck for
updates

Citation: Kim, Y.; Kim, G.; Oh, Y.; Choi, W. Transmission Delay-Based Uplink Multi-User Scheduling in IEEE 802.11ax Networks. *Appl. Sci.* **2021**, *11*, 9196. <https://doi.org/10.3390/app11199196>

Academic Editors: Amalia Miliou and Jungmin So

Received: 12 July 2021

Accepted: 30 September 2021

Published: 2 October 2021

Publisher's Note: MDPI stays neutral with regard to jurisdictional claims in published maps and institutional affiliations.



Copyright: © 2021 by the authors. Licensee MDPI, Basel, Switzerland. This article is an open access article distributed under the terms and conditions of the Creative Commons Attribution (CC BY) license (<https://creativecommons.org/licenses/by/4.0/>).

1. Introduction

As various kinds of uplink wireless services have appeared, improving the spectral efficiency of uplink data transmission in Wi-Fi networks has attracted research attention. A Wi-Fi network can be easily established with a small and simple device called an access point (AP), and anyone or any device can easily connect to the Internet through the AP. The drastically increasing Internet traffic demands require centralized processing at the AP because of a fully random contention-based data transmission procedure that may result in significant performance degradation with a large number of stations participating in contentions, which degrades channel use [1]. In the IEEE 802.11ax standard, the uplink multi-user transmission procedure is specified to increase uplink spectral efficiency by avoiding excessive competition for channel occupation in a Wi-Fi network with many stations trying to transmit uplink data [2]. In the specified uplink multi-user transmission scenario, the AP can trigger simultaneous uplink transmissions to certain stations, and stations triggered to transmit data start their transmissions [3]. After the transmissions from all the triggered stations have been completed, the AP transmits block acknowledgement (ACK) to notify stations of the data reception results. Because the AP specifies the stations that participate in the uplink transmissions, uplink multi-user transmission can be efficiently performed in a network with densely deployed stations trying to transmit

uplink data to the AP [4]. With the proper selection of uplink stations, the channel can be efficiently utilized in data transmissions in a network with many stations rather than to avoid excessive competition. Although centralized scheduling at the AP increases network throughput performance compared to the fully random access-based channel competition of densely deployed stations, scheduling is still an important issue to increase channel use and spectral efficiency in a Wi-Fi network.

An AP allocates frequency-time resource units to stations trying to transmit uplink data, and the number of resource units allocated for each station may be different from each other. For example, by allocating more frequency resources to stations, the stations can transmit much amount of data for the same time. Hence, if stations with different amounts of data are selected for uplink multi-user transmissions, an AP may allocate many resources to stations with a large amount of data to align uplink transmissions to increase channel use. However, if the available resources are limited or in a scenario that multiple stations are supported by multi-user beamforming on a single radio frequency band, transmission delays of selected stations for uplink multi-user transmissions become important to increase channel use. When the transmission delays of scheduled stations are significantly different, the uplink channels during the time between triggering message and block ACK are underutilized, while non-scheduled stations are waiting for transmission opportunities. Inefficient station scheduling without considering the transmission delays of stations degrades channel use, and a delay-considered scheduling method for uplink multi-user transmission is required to improve service performance.

In this paper, we study the open issue regarding the multi-user scheduling process in IEEE 802.11ax networks and propose a transmission delay-based uplink multi-user scheduling method. The proposed scheduling method consists of two parts: station clustering and scheduling of clusters. In the first part, the proposed method creates clusters of stations trying to participate in the uplink transmission process. The clustering is based on the expected transmission delays of stations, and stations with similar transmission delays are clustered together for simultaneous uplink transmission. With transmission delay-based clustering, communication channels between uplink multi-user transmissions from the stations and block ACK transmissions from the AP can be efficiently utilized. Increasing the channel use of the transmission delay-based clustering approach enhances the network throughput performance of the uplink multi-user transmission process specified in the IEEE 802.11ax. In the second part, the proposed method selects the cluster, and stations in the selected cluster are scheduled to transmit uplinks. The clusters are scheduled based on the proportional fair-based approach to enhance network throughput performance without severe degradation in fairness. In this paper, we focus on IEEE 802.11ax networks characterized by simultaneous uplink transmission; however, the proposed scheduling scheme can be applied to any Wi-Fi network, including a Wi-Fi-based sensor/IoT network where the simultaneous uplink transmission is potentially adoptable to improve spectral efficiency.

The contributions of this study are summarized as follows:

- In dense IEEE 802.11ax networks, the uplink multi-user transmission scenario specified in the standard is an efficient solution for improving network throughput performance because of reduced competitions among a large number of stations. However, because block ACK is supposed to be used for uplink multi-user transmissions, the channel would be underutilized when differences in transmission delays of scheduled stations are significant. The proposed method creates clusters of stations so that stations with similar transmission delays are grouped together for uplink multi-user transmissions and enhances the uplink channel use. The proposed method also considers both network throughput and fairness performance by following the proportional fair approach. The trade-off between network throughput and fairness can be easily adjusted by fair proportional parameters.
- The proposed proportional fair-based uplink multi-user scheduling method requires no standard modifications, only simple calculations for scheduling at the AP. High

compatibility with the IEEE 802.11ax standard increases the feasibility of using the proposed method in real-world scenarios. Through the software-defined radio (SDR)-based testbed, we verify the performance of the proposed method.

The remainder of this paper is organized as follows: In Section 2, an overview of related work on the uplink multi-user transmissions is provided. In Section 3, the uplink transmission scenario specified in IEEE 802.11ax and the system model are presented. In Section 4, we explain the proposed station clustering method, and then in Section 4, we propose a proportional fair scheduler based on station clustering. In Section 6, the performance evaluations of the proposed method are presented, and the concluding remarks follow in Section 7.

2. Related Work

2.1. Multi-User Transmissions in IEEE 802.11ax

As the amount of traffic increases, improving the spectral efficiency of IEEE 802.11-based network is becoming increasingly important. One of the solutions for improving spectral efficiency is to use a multi-user multiple-input and multiple-output (MU-MIMO) technique and a multi-user orthogonal frequency division multiple access (MU-OFDMA) technique. These techniques are commonly used in conventional wireless systems requiring high network throughput performance. The gain in OFDMA for IEEE 802.11ax networks has been studied [5,6]. IEEE 802.11 networks also provide multiple wireless connection services based on MU-MIMO and MU-OFDMA with the help of an efficient channel-sounding process such as an appropriate channel-sounding interval decision with low complexity [7]. IEEE 802.11ax also specifies the multi-user transmission scenarios, and various studies of IEEE 802.11ax have been conducted.

Naik et al. analyzed the performance of uplink MU-OFDMA in IEEE 802.11ax networks [8]. In IEEE 802.11ax networks, a buffer status report (BSR) is transmitted to notify an AP of the buffer status of the stations. However, because information such as BSRs should be shared, there is a trade-off between the overall network throughput performance and the capability to support new stations. The authors investigated this trade-off issue in densely deployed IEEE 802.11ax networks. Hoefel studied a channel sounding process for downlink and uplink multi-user transmissions in IEEE 802.11ax [9]. The author presented the comprehensive simulation results of the channel sounding process for the downlink and uplink multi-user transmissions, and analyzed the results regarding the channel sounding compression modes with phase noise, in-phase and quadrature (IQ) imbalance, or carrier frequency offset (CFO) for the performance improvement of multi-user transmissions. Son et al. studied the effects of symbol timing synchronization in uplink multi-user transmissions in IEEE 802.11ax [10]. Asynchronous symbol timing in uplink multi-user transmission may lead to severe performance degradation. To synchronize symbol timing and improve the performance of uplink multi-user transmissions, the authors proposed a two-step synchronization method consisting of coarse symbol timing using a legacy short training field (L-STF) and fine timing synchronization using cross-correlation of a legacy long training field (L-LTF).

Bhattacharai et al. studied multi-user transmissions in two different scenarios: a random access scenario and a scheduled access scenario [11]. The authors showed that the packet arrival rate and the ratio of downlink and uplink traffic affect the throughput performance of IEEE 802.11ax networks, and balancing random access stations and scheduled access stations is important to improve throughput performance. Lanante et al. studied a random access scenario in IEEE 802.11ax networks [12]. The trigger frame from the AP initiates the multi-user transmissions, and non-scheduled stations perform the backoff process for channel access. The authors proposed a hybrid random access method that uses carrier sensing to reduce collisions. They presented an analytical model, and then showed that the hybrid random access method can achieve good performance with enough sensing duration. Lee studied a user selection method that efficiently utilizes channel state information (CSI) in IEEE 802.11ax networks [13]. The CSI estimated from uplink OFDMA frames

were directly used to find the next downlink MU-MIMO users with a good channel quality, which maximized the system utility. In order to improve the efficiency of utilizing CSI from uplink OFDMA for selecting MU-MIMO users, the new OFDMA frame structure allocates all sub-channels to each user sequentially for the last few slots to estimate the CSI of the users.

Bellalta and Kosek-Szott also studied AP-initiated multi-user transmissions in IEEE 802.11ax networks [14]. They investigated the benefit of utilizing multi-user transmissions scenarios under the channel sounding process specified in IEEE 802.11ax, and suggested adjusting the contention window size to further improve throughput performance by avoiding collisions between AP- and user-initiated transmissions. Kawamura et al. presented cooperative control methods for uplink multi-user transmissions in IEEE 802.11ax networks [15]. The first method involves adjusting the spatial reuse parameters. The second method involves scheduling stations using hierarchical clustering, in which basic service sets whose mutual interference is small are clustered together. Kotagiri et al. studied a multi-user spectrum access method for IEEE 802.11ax-enabled stations [16]. In IEEE 802.11ax networks, stations may access the network by randomly selecting a subchannel among the available subchannels. The authors applied convolution neural network (CNN)-based deep reinforcement learning for selecting the subchannel. Each station locally trains its CNN based on the energy detection of channels and ACK packets without requiring centralized training.

The above works focused on balancing the AP-initiated multi-user transmissions and user-initiated transmissions with a back-off process for channel access, increasing transmission success probability by spatially clustering the stations with APs, or increasing channel access probability of stations using channel learning techniques. In this study, we focused on the scheduling of uplink multi-user transmissions in a dense IEEE 802.11ax network. The proposed method enhances channel use by clustering stations with similar transmission delays for uplink multi-user transmissions in a network where a large number of stations are deployed.

2.2. Proportional Fair-Based Scheduling

Proportional fairness is widely used because of its efficiency in improving both throughput and fairness performance. Fu and Kim analyzed the throughput and fairness performance of scheduling methods, including proportional fair-based scheduling [17]. Through the numerical analysis, the authors showed that the proportional fair-based scheduling method provides relatively better trade-offs between throughput and fairness compared to the round-robin and maximum carrier-to-interference ratio scheduling methods. Checco and Leith studied the proportional fair-based rate allocation problem in IEEE 802.11 networks [18]. Within the possible achievable rate region, they proposed a rate allocation method on the basis of air time information. Under some assumptions, such as interference is limited and stations are backlogged, the proportional fair-based rate allocation showed optimal performance in IEEE 802.11 networks. The proportional fairness-based user scheduling approach has been studied in MU-MIMO or OFDMA systems. Shen et al. studied proactive proportional fairness scheduling based on channel prediction in OFDMA systems [19]. Using the predicted channel information, they proposed a proportional fair-based resource allocation method. Their findings showed that proportional fairness-based scheduling has the potential to improve network performance combined with other techniques such as channel predictions. Budhiraja et al. studied deep reinforcement learning based resource allocation and a power control method with proportional fairness in device-to-device communications [20]. In the proposed method, utility function for proportional fairness of device-to-device pairs is used for resource allocation.

In this study, we used the proportional fair-based scheduling approach to further improve the performance of our previously reported method. Our previous work shows that transmission delay-based scheduling improves the throughput performance in IEEE

802.11ax networks [21]. In the transmission delay-based scheduling method, stations with similar transmission delays are clustered together to simultaneously transmit uplink data. By scheduling stations with similar transmission delays, the channels can be efficiently utilized in the uplink multi-user transmission scenario in IEEE 802.11ax networks. We further improved the transmission delay-based scheduling method so that the proposed method would show good throughput performance in a network with a large number of stations. We applied a proportional fair-based approach in the transmission delay-based scheduling method to efficiently improve throughput performance while maintaining good fairness among the stations. After the transmission delay-based station clustering, a clustering-based proportional fair approach is adopted to select clusters for uplink multi-user transmissions. The proposed method also performs re-clustering so that differences in transmission delays of stations do not significantly increase, resulting in low channel use. Through the various IEEE 802.11-compliant simulations and SDR-based experiments, we show the feasibility of the proposed scheduling method in IEEE 802.11ax networks.

3. System Model

In this paper, we consider an uplink multi-user transmission scenario in an IEEE 802.11ax-enabled network, which consists of one AP and non-AP stations. Let an IEEE 802.11ax-enabled AP and non-AP stations associated with the AP be a_S and $\mathcal{S} = \{s_1, s_2, \dots, s_S\}$, respectively. In the network, with the help of MU-MIMO and OFDMA techniques, the AP a_S can simultaneously receive multiple data streams transmitted from multiple stations in \mathcal{S} . To perform uplink multi-user transmissions, the channel state information (CSI) between the AP and each station should be notified in advance. In the IEEE 802.11ax standard, the channel-sounding process for obtaining CSI is specified as follows: First, AP broadcasts a null data packet (NDP) announcement followed by an NDP to initiate the channel sounding process. After, AP transmits a beamforming report (BFRP) trigger frame and the station's response to the BFRP trigger by sending the CSI to the AP. In the channel-sounding process, the BFRP trigger frame can be transmitted repeatedly to more than one sequence to obtain the CSI of all stations in the network. Note that the buffer status information of stations can also be notified to the AP jointly with the channel sounding process. In IEEE 802.11ax standard, the buffer status response (BSR) can be implicitly reported in the QoS control field or BSR control field as well as explicitly reported following by the BSR poll (BSRP) trigger from the AP.

We denote the channel between each station and AP estimated during the channel sounding process by \mathbf{H}_{a_S, s_i} . Then, the signal-to-interference plus noise power of each uplink signal from a station to the AP is given as follows:

$$\gamma_{a_S, s_i} = \frac{p_{s_i} |\mathbf{H}_{a_S, s_i}|^2}{\sum_{a_j \in \mathcal{S}} p_{a_j} |\mathbf{H}_{a_S, s_j}|^2 + \sigma^2}, \quad (1)$$

where p_{s_i} is the transmission power of s_i and σ^2 is noise power. The maximum uplink transmission rate of each station depends on the expected SINR γ_{a_S, s_i} and modulation and coding scheme (MCS) specified in IEEE 802.11ax. In this paper, we assume that each station tries to transmit data with the maximum transmission rate, and denote the mapping function that introduces the uplink transmission rate by $R_{s_i}(\cdot)$, i.e., the transmission rate of station s_i is given as $R_{s_i}(\gamma_{a_S, s_i})$. After the RTS and CTS procedure, the uplink channel can be estimated, and the appropriate MCS level is decided by the AP and notified to stations using triggering messages. For simplicity, in this paper, we assume that each uplink transmission has the same bandwidth, and denote the maximum capacity of the simultaneous uplink multi-user transmissions in the network by B_{a_S} . In other words, the AP a_S can receive at most B_{a_S} data streams at the same time.

In the uplink multi-user transmission scenario in IEEE 802.11ax, an AP can allow up to S stations to transmit their data simultaneously with rate $R_{s_i}(\gamma_{a_S, s_i})$ for each station s_i . An uplink multi-user transmission generally improves network throughput performance by

avoiding spectral inefficiency caused by excessive competition among stations. However, if there are huge differences in transmission delays among the stations selected for uplink multi-user transmissions, the network throughput performance may degrade owing to low channel use. Figure 1 depicts the uplink multi-user transmission scenario with one AP and three non-AP stations in an IEEE 802.11ax network [21]. First, AP a_S transmits a multi-user request-to-send (RTS) frame to stations s_1 , s_2 , and s_3 . Then, stations respond to the RTS by sending clear-to-send (CTS) frames to the AP. Second, the AP transmits trigger frames that contain scheduling information. The scheduled stations transmit uplink data streams to the AP. After the reception of uplink data transmissions from the scheduled stations, the AP is supposed to transmit a block ACK to stations as an efficient and simple response mechanism in IEEE 802.11ax. Note that the RTS/CTS mechanism is determined by the length of the transmitted data frame [22]. If the data size is larger than the threshold, data transmission is processed by the RTS and CTS mechanism. The uplink multi-user transmission considered in this paper follows the RTS/CTS mechanism in IEEE 802.11 networks.

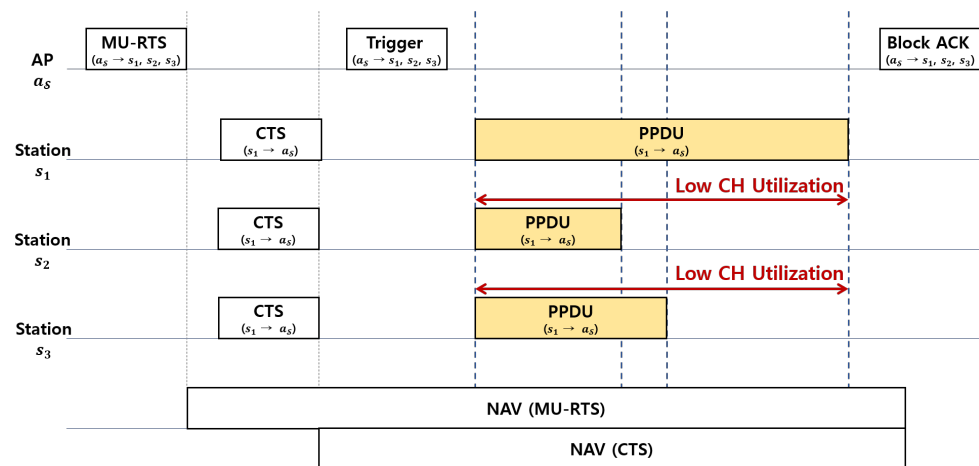

Figure 1. An example of uplink multi-user transmissions in IEEE 802.11ax networks.

However, as shown in Figure 1, inappropriate station scheduling for uplink transmissions results in low channel use. The stations may transmit different sizes of data with different transmission rates, i.e., there are differences in the transmission delays of the scheduled stations for uplink transmissions. Although frame aggregation or fragmentation may mitigate the problem of low channel use, the transmission delay difference of scheduled stations is still important to increase channel use in uplink multi-user transmissions, especially for the scenario with multi-user beamforming on a single radio frequency band. Note that the feasibility of frame aggregation depends on the amount of backlogged data, and stations with a small amount of aggregated data cannot be aligned with stations with a large amount of data. On the other hand, the uplink data of stations with a large amount of data can be split into multiple fragments to align transmission delays with stations with a small amount of uplink data. However, in this case, stations performing fragmentation eventually require more transmission opportunities to transmit multiple fragmented data. The network overhead also increases compared to the non-fragmented transmissions; thus, performing fragmentation without considering transmission delay-based station selection is inefficient for a dense network.

In addition, as the transmission delay difference among scheduled stations becomes larger, the network allocation vector (NAV) lengthens, and non-scheduled stations have less transmission opportunity even when channels are not occupied by stations. In dense IEEE 802.11ax networks where a large number of stations is deployed for uplink transmissions, an increase in NAV with underutilized channels for uplink multi-user transmissions may significantly degrade the throughput performance while decreasing the transmission opportunities of non-scheduled stations. To improve channel use for uplink multi-user

scenarios in dense IEEE 802.11ax networks, the proposed method follows clustering-based scheduling so that stations with similar expected transmission delays are scheduled together. Stations are grouped into multiple clusters, and the proposed method selects clusters for uplink multi-user transmissions. The cluster selection is based on the proportional fair approach, which is widely used for schedulers considering both network throughput and fairness performance. The proposed transmission delay-based scheduling approach for uplink multi-user transmissions improves channel use and network throughput performance in IEEE 802.11ax.

The proposed transmission delay-based scheduling method consists of two steps, and each step is designed to improve channel use and the fairness of stations for uplink transmission, separately. First, stations having uplink transmission data are clustered on the basis of their transmission delay so that the channel use improves [21]. The AP calculates the transmission delay of stations and forms clusters so that stations with similar transmission delays are clustered together. Second, the cluster for uplink multi-user transmission is selected following proportional fair-based scheduling. The proportional fairness is calculated for each cluster, and the AP decides the cluster for uplink multi-user transmission. In the following sections, we describe the detailed procedure for each step of the proposed scheduling method.

4. Transmission Delay-Based Station Clustering

4.1. Clustering-Based Channel use Improvement

Stations may perform frame aggregation for uplink multi-user transmissions. The channel will be underutilized if transmission delays of the scheduled stations are different from each other because of various amounts of backlogged data or transmission rates. In the proposed scheduling method, stations with similar transmission delays are clustered together [21]. In order to acquire the CSI, the channel sounding process is performed in advance. After channel sounding, the SINR information for each uplink station is given as (1), and the uplink transmission rate of each station is given as $R_{s_i}(\gamma_{a_S, s_i})$. Note that $R_{s_i}(\gamma_{a_S, s_i})$ can be decided following the link adaptation strategy in the network. Let Q_{s_i} denote the size of uplink data in which station $s_i \in \mathcal{S}$ attempts to transmit to the AP. The Q_{s_i} can be an aggregated payload for uplink transmissions, i.e., aggregated MAC protocol data unit pre-end-of-frame padding. Stations in the network have different data transmission rates and queue sizes for uplink data transmissions. If there are stations that have no data in their queue, they are excluded from the uplink scheduling. For the stations requiring uplink data transmissions, the transmission delay of station s_i can be simply calculated as follows:

$$d_{s_i} = Q_{s_i} / R_{s_i}(\gamma_{a_S, s_i}). \tag{2}$$

Note that each station may have different transmission delays $d_{s_i}, s_i \in \mathcal{S}$. The proposed method creates station clusters based on the transmission delay d_{s_i} of each station so that stations with similar transmission delays are configured to transmit uplink data simultaneously. Let $\mathcal{C}^{UL} = \{\mathcal{C}_1^{UL}, \mathcal{C}_2^{UL}, \mathcal{C}_3^{UL}, \dots\}$ be the set of station clusters, where $\mathcal{C}_l^{UL} = \{\{s_i\} | s_i \in \mathcal{S}\}$ and $\mathcal{C}_l^{UL} \cap \mathcal{C}_m^{UL} = \emptyset$, for $\mathcal{C}_l^{UL}, \mathcal{C}_m^{UL} \subset \mathcal{C}^{UL}$. We define the function representing the difference in transmission delays between any two stations in the same cluster by $\tau(d_{s_i}, d_{s_j}) = |d_{s_i} - d_{s_j}|, s_i \neq s_j \in \mathcal{C}_l^{UL}$ for $\mathcal{C}_l^{UL} \subset \mathcal{C}^{UL}$. In the proposed method, clusters are configured to minimize the maximum difference in the transmission delay of clusters, and the station clustering problem is formulated as follows:

$$\begin{aligned} & \min \max_{d_{s_i}, d_{s_j} \in \mathcal{C}_l^{UL}, \mathcal{C}_l^{UL} \subset \mathcal{C}^{UL}} \tau(d_{s_i}, d_{s_j}) \\ & \text{subject to} \quad 1 \leq |\mathcal{C}_l^{UL}| \leq B_{a_S}, \mathcal{C}_l^{UL} \subset \mathcal{C}^{UL} \\ & \quad \quad \quad s_i \in \mathcal{C}^{UL}, \forall s_i \in \mathcal{S}. \end{aligned} \tag{3}$$

Note that if there are available frequency bands owing to a small number of stations participating in uplink multi-user transmissions, i.e., $|\mathcal{C}_l^{UL}| < B_{a_S}$, the available frequency

resources can also be utilized by downlink transmissions or channel sounding for newly joining stations. Hence, in this paper, we focus on the uplink multi-user transmissions, and the proposed method tries to fully utilize available bandwidths by employing the maximum number of stations for uplink multi-user transmissions. If we assume that the stations are clustered to maximize the cluster size and the maximum number of stations is scheduled to transmit uplink data simultaneously, i.e., $|C_l^{UL}| = B_{a_S}$, the problem in (3) can be easily solved following a greedy approach. For example, stations are sorted based on transmission delays, then stations are sequentially grouped into the same cluster until the number of stations in the cluster reaches the maximum capacity of simultaneous uplink transmissions B_{a_S} . After, for the remaining stations, the same procedure can be repeated.

4.2. Numerical Analysis of Channel Use

In this section, we present the channel use efficiency of the proposed transmission delay-based station clustering. The proposed station clustering method improves the uplink channel use of multi-user transmissions following the scenarios specified in IEEE 802.11ax. On the basis of the CSI and BSR from stations trying to participate in uplink multi-user transmissions, the expected transmission delay of each station is calculated. Then, the stations with similar transmission delays are clustered together for simultaneous uplink transmissions. We analyzed the performance of the proposed transmission delay-based station clustering, and show that the proposed method improves the channel use of uplink multi-user transmissions in IEEE 802.11ax.

To prove the concept of transmission delay-based station clustering, we compare the normalized channel use through simulations with a simplified toy model. In the toy model, the PPDU size of a single frame is uniformly distributed, and information about the transmission delays of stations is assumed to be known for the clustering method described in Section 4.1. We define the normalized channel use as the average transmission delay normalized by the maximum one among the selected stations. In this simulation, the transmission rates of stations selected for uplink transmissions are all assumed to be the same, and packet arrival rates follow the Poisson distribution. Note that if the transmission rates are all the same for the selected stations for uplink multi-user transmissions, the PPDU size is directly related to the transmission delay. Hence, if all the uplink PPDU sizes of the selected stations are the same, the normalized channel use is 1. As the normalized channel use approaches 1, channels become less underutilized during the time between the end of the PPDU transmissions and the start of block ACK transmission. We compare the channel use of the transmission delay-based clustering method with periodic re-clustering, transmission delay-based clustering method without re-clustering, and the random selection method. In the simulations, the number of simultaneous uplink transmissions was set to 8, i.e., 8 stations were selected.

Figure 2 shows the channel use results regarding transmission time when 8 out of 16 stations were selected for uplink transmissions. From the results, transmission delay-based station clustering shows higher channel use performance than the random selection method. However, the performance of the transmission delay-based clustering method without re-clustering degrades over time, while the random selection method shows consistent channel use performance. This is because the transmission delay changes over time according to the transmission environments, such as packet arrival rates or transmission rates. To compensate for the changes in transmission environments, stations should be re-clustered based on expected transmission delays. The transmission delay-based clustering method with re-clustering performs station clustering every 5 times, and it shows better channel use performance compared than the other methods. Figure 3 shows the channel use results with regard to transmission time when there are 24 stations. The simulation result is similar to the one shown in Figure 2, but it indicates that re-clustering becomes more important in the network with many stations. Note that transmission delay calculations need the BSR and CSI from stations trying to participate in uplink multi-user

transmissions. Hence, performing station clustering every transmission increases overhead, and the throughput performance may degrade.

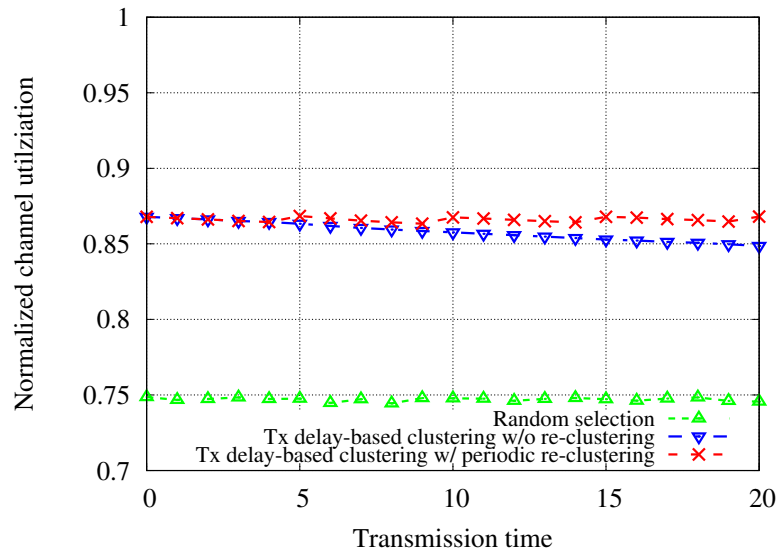

Figure 2. Normalized channel use (packet arrival rate and transmission rate are same). There are 16 non-AP stations.

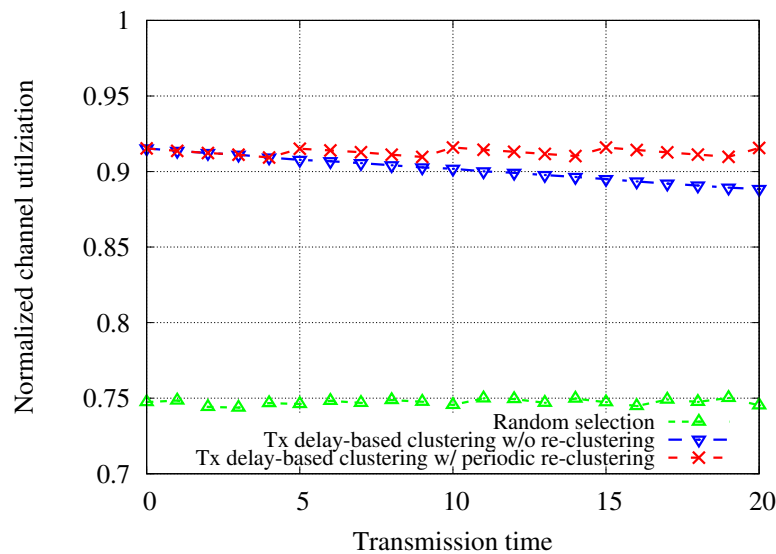

Figure 3. Normalized channel use (packet arrival rate and transmission rate are same). There are 24 non-AP stations.

Through the concept-proof simulations, we show that the transmission delay-based station clustering can improve channel use, which is directly related to the network throughput performance. We also show that re-clustering should be performed for the station clustering-based method to follow the changes in uplink transmission environments. Note that re-clustering also enhances the fairness among stations compared to the transmission delay-based clustering method without re-clustering. In the following section, we propose a proportional fair scheduler that is based on a station cluster.

5. Proportional Fair-Based Transmission Scheduling

5.1. Clustering-Based Proportional Fair Scheduler

In the proposed method, stations are first clustered on the basis of transmission delay, and then the AP schedules clusters to transmit uplink data. Note that stations with

similar transmission delays are clustered together to enhance channel use and network throughput performance in the uplink multi-user scenario. With highly efficient clusters for the uplink multi-user transmission scenario in IEEE 802.11ax networks, we propose a cluster scheduling method on the basis of a proportional fair-based approach. Proportionally fair scheduling enhances network throughput as well as the fairness of stations trying to transmit data by adjusting the priority of stations inversely proportional to their previous resource consumption. The proportional fair-based method is one of the widely used scheduling approaches, because it can achieve good performance both in network throughput and fairness among stations. In the proposed method, higher transmission opportunity can be achieved, as stations are starving to transmit uplink data and have shorter transmission delays.

The proposed method performs scheduling after the stations are clustered together on the basis of their transmission delays as in (3). Let $v_{C_l^{UL}}^t$ be the proportional fairness value of cluster l ($C_l^{UL} \subset C^{UL}$) at time slot t . We denote the transmission rates of station s_i , $s_i \in \mathcal{S}$ at time slot t as $R_{s_i}^t(\gamma_{a_S, s_i})$. In this paper, we define proportional fairness on the basis of transmission delay, so that uplink multi-user transmission delay is minimized in IEEE 802.11ax networks. The proposed proportional fairness value of each cluster is defined as follows:

$$v_{C_l^{UL}}^t = \frac{\{\sum_{s_i \in C_l^{UL}} R_{s_i}^t(\gamma_{a_S, s_i})^{-1}\}^\alpha}{\{\frac{1}{T} \sum_{k=t-T}^{t-1} \sum_{s_i \in C_l^{UL}} R_{s_i}^k(\gamma_{a_S, s_i})^{-1}\}^\beta}, \tag{4}$$

where α and β are the adjustment values for balancing transmission delay and fairness performance, respectively. For example, for $\alpha = 1$ and $\beta = 0$, the proportional fairness value is the sum of transmission delays of stations in the cluster. On the other hand, for $\alpha = 0$ and $\beta = 1$, clusters are scheduled in a round-robin manner. Note that the averaging duration T is adjustable within the hardware limitations.

In the proposed method, proportional fairness value of all clusters in C^{UL} is calculated at every scheduling period, and the cluster with the minimum value is scheduled for uplink data transmission. The cluster scheduling problem for multi-user uplink transmissions at time t is formulated as follows:

$$\arg \min_{C_l^{UL} \in C^{UL}} v_{C_l^{UL}}^t. \tag{5}$$

Equation (5) can be easily solved by comparing the proportional fairness value of clusters in C^{UL} . After finding the cluster with the minimum value, the stations in the selected cluster are scheduled for simultaneous uplink multi-user transmissions. Note that the proposed scheduling method efficiently enhances uplink channel use and network throughput performance by clustering stations with similar transmission delays and avoids the channel access starving of stations by exploiting proportional fairness.

5.2. Re-Clustering Condition Based on Transmission Delay

The performance of the proposed scheduling method depends on the difference in the transmission delays of the stations. Hence, if data sizes or transmission rates for uplink transmissions considerably change after the clustering, the channel use lowers, and the performance of the proposed method eventually degrades. In order to compensate for the performance degradation, the stations should be re-clustered when the difference in transmission delays exceeds a certain threshold.

The re-clustering condition of the proposed method occurs on the basis of the changes in transmission delays. Let the time that stations are clustered be t' . At time t' , maximum transmission delays of each cluster can be calculated, and we denote the difference in transmission delay of the cluster with the largest value as $\tau_{max}^{t'}$. At every time t , the cluster for performing uplink multi-user data transmission is selected by solving (5), and we denote the cluster selected at time t as $C_{*}^{UL, t}$. Before notifying the stations of scheduling information by transmitting a triggering frame, the AP compares the maximum transmission delay of

the currently selected cluster $C_*^{UL,t}$ with τ'_{max} . The proposed method performs re-clustering when the following condition is satisfied:

$$\max\{\tau(d_{s_i}^t, d_{s_j}^t)\} > \lambda \cdot \tau'_{max}, \text{ for } s_i, s_j \in C_*^{UL,t}, \quad (6)$$

where λ is an adjustable parameter, which can be changed depending on the network topology or channel environments. In the proposed method, re-clustering is performed by comparing the current transmission-delay difference with the one for the initial clustering to maintain reasonable channel use for uplink multi-user transmission without considerable performance degradation. Note that λ is supposed to be greater than or equal to 1. This is because the amount of uplink data of stations and channel states can be changed, and the transmission-delay difference at time $t > t'$ is likely to be larger compared to the one at time t' . In the following section, we set λ as 1.5 or 1.9 for the evaluations. The re-clustering is performed more frequently when λ is 1.5 than 1.9.

6. Performance Evaluation

We conducted performance evaluations of uplink multi-user scheduling using MATLAB. In the network topology where an AP and multiple stations are deployed, multiple stations participate in the uplink multi-user transmissions. As shown in Figure 1, the AP broadcasts an MU-RTS, and stations respond by transmitting a CTS. After collecting the transmission information, including buffer status and channel state, the proposed uplink multi-user scheduling method divides the stations into multiple clusters so that stations with similar expected delays are grouped together to transmit uplink data. The clusters are selected based on a proportional fair strategy or in a round-robin manner. We compared the proposed method with delay-based clustering with round-robin selection method, delay-based clustering with random selection method, and random selection method without clustering. In the proposed method, network throughput and fairness performance can be managed by adjusting α and β , and three kinds of α and β combinations were compared in the simulation. Parameters α and β are decided depending on the operation policy of Wi-Fi service providers. Table 1 shows the simulation parameters for the uplink transmission scenarios in IEEE 802.11ax networks as in [14]. The required duration for channel sounding process is also considered as in [14]. The aggregated MAC protocol data unit (A-MPDU) pre-EOF padding (APEP) sizes of stations deployed in the network are randomly selected between 0 and 4097 bytes, and the MCS is set between 0 and 11 following the channel state between each station and the AP. In the simulations, channel status between stations and the AP were assumed to be asymmetric, which means that uplink transmissions may experience different channel conditions. This is more realistic than the symmetric channel scenario where all the stations experience the same channel conditions. Note that in the network scenario where all the stations experience a similar channel environment, the performance may predominantly depend on the data lengths.

Table 1. IEEE 802.11ax simulation parameters.

Parameter	Value	Parameter	Value
SIFS	16 μ s	Service field length	16 (bits)
AIFS	34 μ s	MPDU delimiter length	32 bits
Legacy preamble	20 μ s	MAC header length	320 bits
HE preamble	168 μ s	Tail length	18 bits
Max APEP size	4096 Bytes	RTS	160 bits
Max buffer size	256,000 bits	CTS	112 bits

6.1. Uplink Transmission in Stable Channel Environment

Figures 4 and 5 show the network throughput and fairness performance when there are 200 stations in the network. The uplink channels were assumed to be stable; thus, MCSs did not change during the simulation time. As shown in Figure 4, network throughput performance increased as the number of simultaneous uplink transmission increased. For all the uplink cases with a different number of simultaneous transmissions, the proposed delay-based clustering with proportional fair selection performed better than other methods. Note that as α increases and β decreases, clusters are selected to increase throughput performance; thus, the proposed method with $\alpha = 0.8$ and $\beta = 0.2$ produced the highest throughput performance. As α decreases and β increases, the throughput performance of the proposed method becomes close to that of round-robin-based cluster selection. The simulation results also showed that the delay-based clustering performed better than the method without clustering. This is because transmission delay-based clustering increases channel use between the uplink data transmissions from stations and a block ACK transmission from an AP. The results also indicated that the proposed method provides better throughput performance than the other methods in a heavily dense network where a large number of stations is deployed for uplink transmissions.

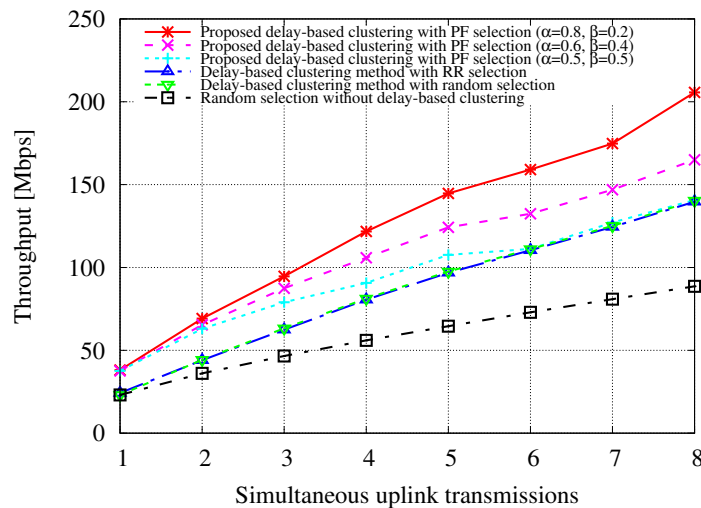

Figure 4. Network throughput performance ($S = 200$).

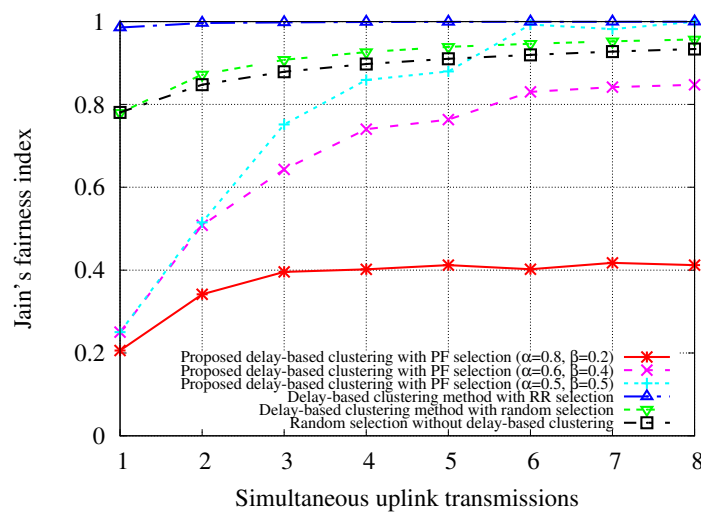

Figure 5. Fairness performance ($S = 200$).

Figure 5 shows the fairness performance with regard to the number of simultaneous uplink transmissions. The fairness performance was measured based on the amount of transmitted data of stations and calculated using Jain's fairness index. The results showed that transmission delay-based clustering with round-robin selection produced the highest fairness. This is because clusters are selected to transmit uplink data, and stations are fairly scheduled. On the other hand, proposed delay-based clustering with proportional fair selection shows lower fairness performance because clusters are selected to maximize throughput performance rather than fairness. However, as α decreased and β increased, the fairness performance of the proposed method with proportional fair selection increased. The fairness performance of the proposed method with $\alpha = 0.5$ and $\beta = 0.5$ becomes similar to the fairness performance of the delay-based clustering method with round-robin selection when the number of simultaneous uplink transmissions is greater than or equal to six.

Figure 6 shows the network throughput performance when there are 100 stations in the network. The throughput performance is similar to the results in Figure 4. Compared to the throughput performance results in Figure 4, the difference in throughput performance between the proposed delay-based clustering with proportional fair selection and delay-based clustering with round-robin selection decreases, especially when $\alpha = 0.5$ and $\beta = 0.5$. This is because as the number of stations decreases, the cluster candidates to be selected for uplink transmissions decrease. However, when $\alpha = 0.8$ and $\beta = 0.2$, the network throughput performance of the proposed method performs much better than the other methods. Note that the performance gain of the proposed method compared to the other method increases when a large number of stations are deployed in the networks.

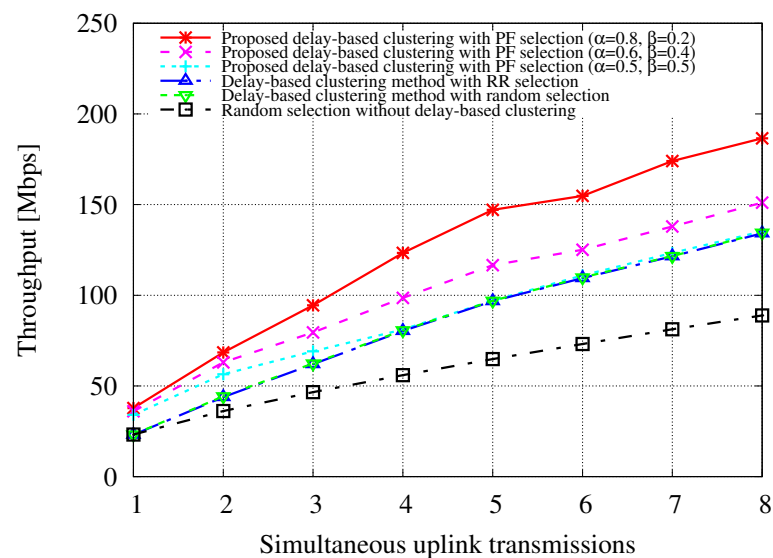

Figure 6. Network throughput performance ($S = 100$).

The simulation results showed that the proposed delay-based clustering with proportional fair selection enhances the network throughput performance of multi-user uplink transmission scenarios in IEEE 802.11ax networks. In addition, by adjusting the proportionally fair parameters, α , and β , the fairness performance would increase.

6.2. Uplink Transmission in Unstable Channel Environment

Figures 7 and 8 show the network throughput performance when uplink channels are assumed to be unstable and MCSs of 80% and 40% of stations change every simulation time, respectively. For the proposed method with a re-clustering strategy, λ is set to 1.5, and the methods perform re-clustering if the condition in (6) is satisfied. The simulation results show that the network throughput performance decreases as the channel becomes unstable, i.e., more stations experience MCS change owing to the time-varying channels between

stations and the AP. For the same values of α and β , the proposed method with re-clustering shows better throughput performance than the proposed method without re-clustering. This implies that performing re-clustering is important for enhancing network throughput performance in a time-varying channel environment. Moreover, for the uplink transmission scenarios in Figure 7, the proposed method with re-clustering ($\alpha = 0.6$ and $\beta = 0.4$) shows similar throughput performance to the proposed method without re-clustering ($\alpha = 0.8$ and $\beta = 0.2$).

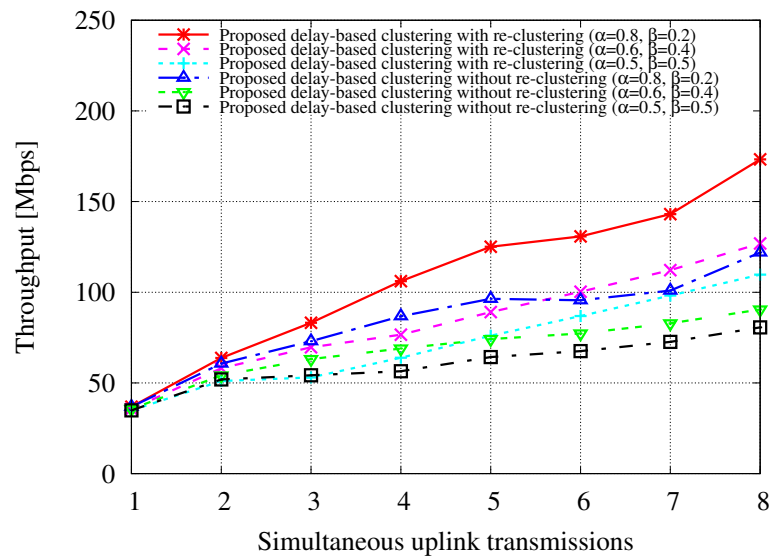

Figure 7. Network throughput performance (MCS of 80% stations changes, $\lambda = 1.5$).

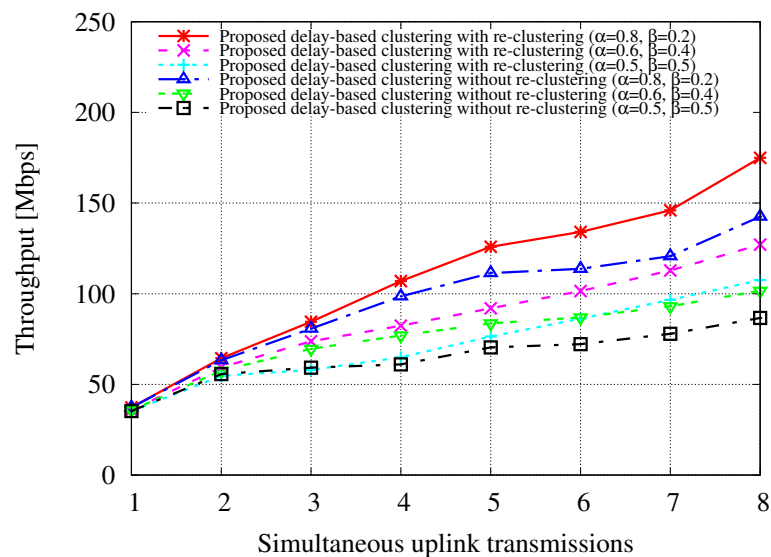

Figure 8. Network throughput performance (MCS of 40% stations changes, $\lambda = 1.5$).

Figures 9 and 10 shows the fairness performance of the proposed method in an unstable channel environment. As in the results in stable uplink scenarios, fairness performance increases as α decreases and β increases. On the other hand, the simulation results show similar fairness performance regardless of the channel environment. By performing station re-clustering based on transmission delay in an unstable channel environment, throughput performance can be increased while maintaining fairness performance.

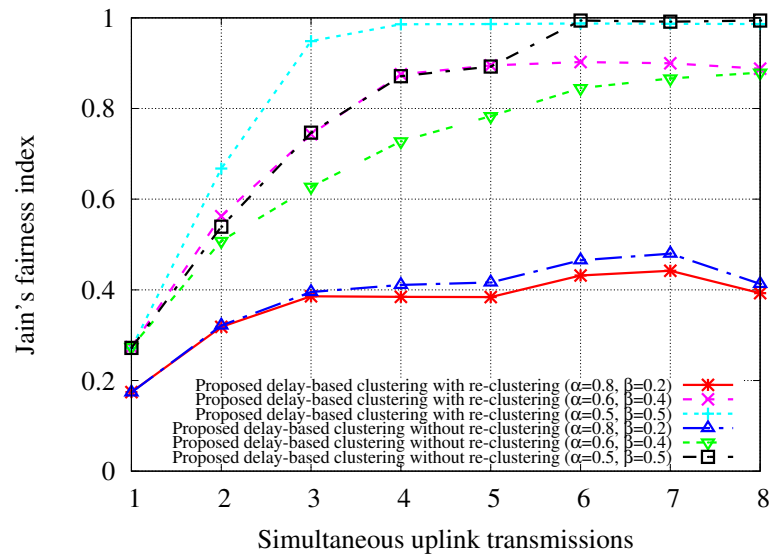

Figure 9. Fairness performance (MCS of 80% stations changes, $\lambda = 1.5$).

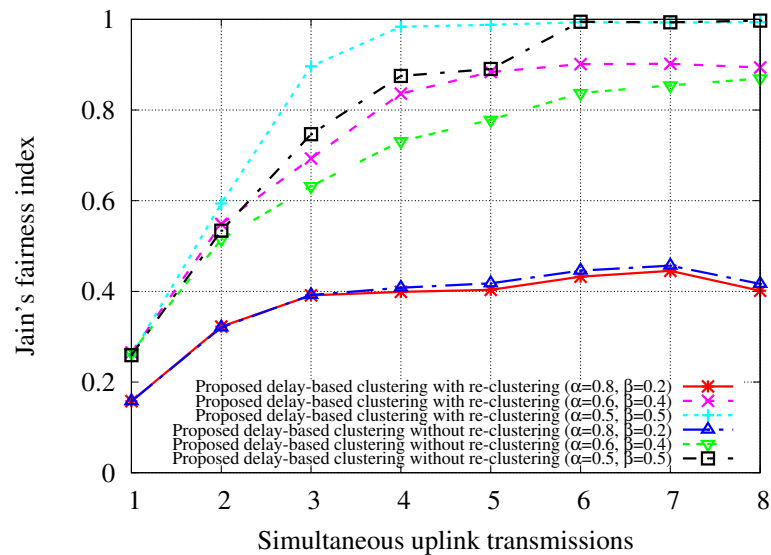

Figure 10. Fairness performance (MCS of 40% stations changes, $\lambda = 1.5$).

Figures 11 and 12 show the network throughput performance in an unstable channel when MCSs of 80% and 40% of stations change every simulation time, respectively. Unlike the performance evaluations in Figures 7 and 8, λ for performing re-clustering as in (6) is set to 1.9 instead of 1.5. As shown in the results, with an increased value of λ , the proposed method with re-clustering shows similar performance with the proposed method without re-clustering method. In Figure 11, the performance of the proposed method with re-clustering approaches that of the proposed method without re-clustering compared to the results in Figure 12. This implies that λ should be adjusted to a smaller value as channels between stations and an AP becomes unstable.

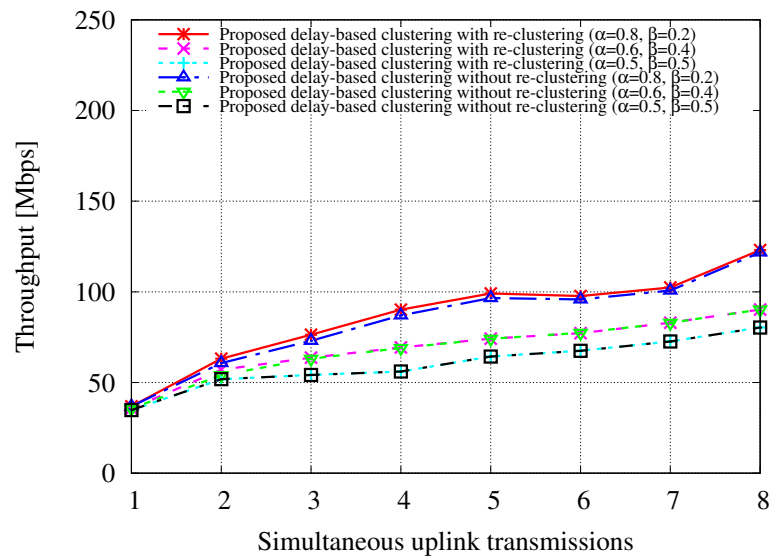

Figure 11. Network throughput performance (MCS of 80% stations changes, $\lambda = 1.9$).

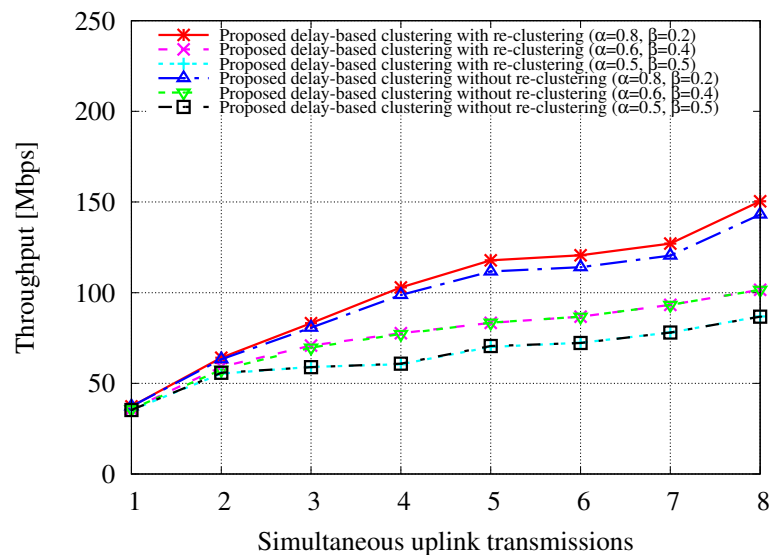

Figure 12. Network throughput performance (MCS of 40% stations changes, $\lambda = 1.9$).

Through the various simulations, we found that the proposed method can improve the network throughput performance in dense networks with a large number of stations. Note that the proposed method has relatively higher complexity than the other methods because the proposed method has to sort stations based on their transmission delays to create clusters, and cluster-based proportional fair scheduling is performed, while other methods do not need sorting for clustering. However, with the SDR-based experiments described in the following section, we demonstrate the feasibility of the proposed method in real-world scenarios.

6.3. Software-Defined Radio Equipment-Based Experiments

We verified the proposed method with SDR equipment-based experiments as shown in Figure 13. We deployed one Universal Software Radio Peripheral (USRP) as an AP and four USRPs as stations trying to transmit uplink data to the AP. The host computer performs uplink scheduling of stations, and scheduled information is transmitted to the stations through the Ethernet. After, selected stations perform uplink transmissions to the AP, which is connected to the computer for analyzing the received data. With the USRP-based testbed, we examined the channel use of simultaneous uplink transmissions.

With the parameters in Table 1, channel use was measured by estimating the average transmission delay compared to the maximum among the scheduled stations.

Figure 14 shows the experimental results of channel use in a simultaneous uplink scenario. The optimal re-clustering method performs re-clustering every time slot and produced the highest channel use performance. This method may significantly increase the overhead for the network with a large number of stations. However, in the experiments with four uplink stations, the optimal re-clustering method showed the best performance. The results showed that the proposed delay-based clustering with the re-clustering method shows higher channel use performance compared to the other methods, except the method performing re-clustering every time. Although the proposed method without re-clustering shows lower channel use performance than the proposed method with re-clustering, its performance is still higher than the round-robin selection or random selection methods. With the SDR-based testbed, we verified the efficiency of the proposed method for uplink multi-user transmissions.

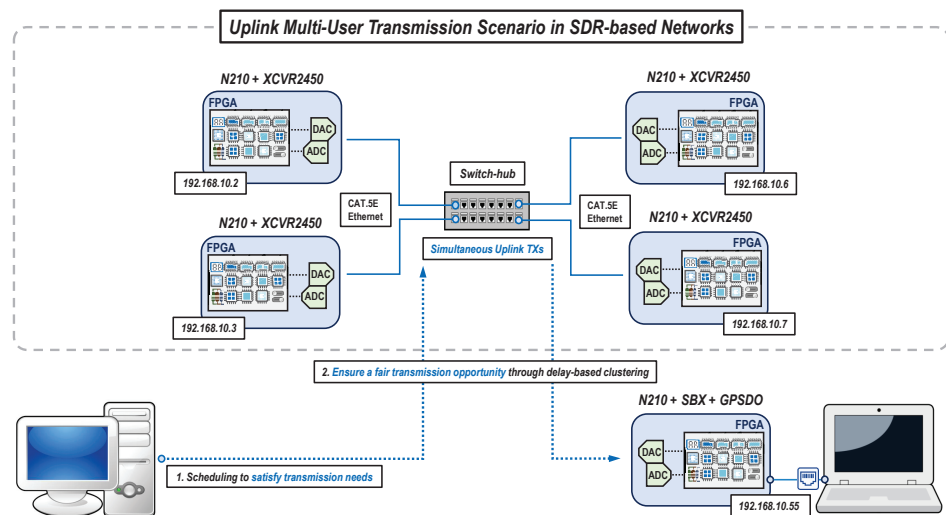

Figure 13. Software-defined radio equipment-based testbed for uplink transmissions.

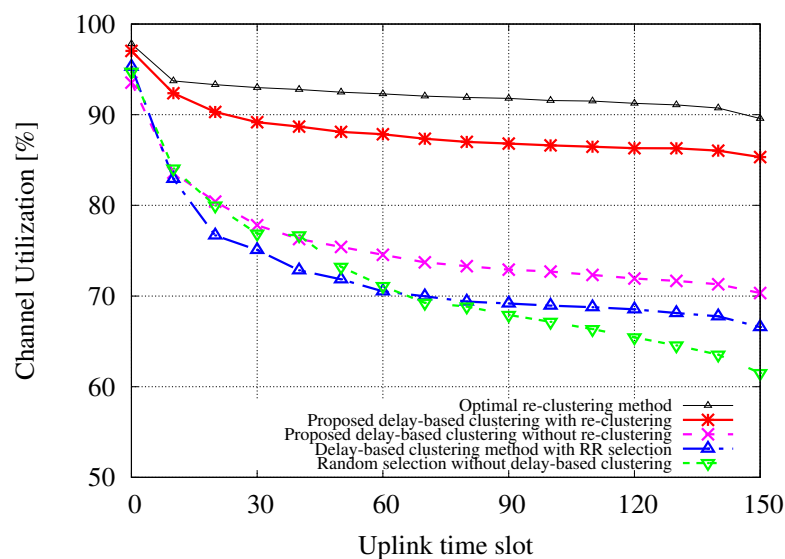

Figure 14. Channel use performance.

7. Conclusions

In this paper, the proportional fair-based uplink multi-user scheduling method was proposed. The proposed method clusters stations based on transmission time to efficiently improve channel use and performs proportional-based scheduling for clusters to improve the network throughput performance. Through the various simulations and SDR-based experiments, we showed that the proposed method improves network throughput performance with enhanced channel use in dense IEEE 802.11ax networks. In future work, transmission delays of stations could be cooperatively exploited for scheduling with beamforming gains that are affected by channel coefficients between the AP and selected stations. Multi-user beamforming can be performed on a single radio frequency to simultaneously support uplink stations. In dense networks where a large number of stations is deployed, the data arrival of stations, beamforming gains for supporting selected stations, and station clustering for simultaneous transmissions should be learned and decided in real-time to efficiently increase the performance of wireless connectivity services.

Author Contributions: Conceptualization, Y.K.; methodology, Y.K.; software, Y.K. and G.K.; validation, Y.K. and Y.O.; formal analysis, Y.K.; investigation, Y.K.; resources, Y.K.; data curation, Y.K. and G.K.; writing—original draft preparation, Y.K.; writing—review and editing, Y.K. and W.C.; visualization, Y.K., G.K. and Y.O.; supervision, W.C.; project administration, W.C.; funding acquisition, W.C. All authors have read and agreed to the published version of the manuscript.

Funding: This work was supported by the research fund from Chosun University, 2021.

Institutional Review Board Statement: Not applicable.

Informed Consent Statement: Not applicable.

Data Availability Statement: Not applicable.

Conflicts of Interest: The authors declare no conflict of interest.

References

1. Chen, Q.; Zhu, Y.-H. Scheduling channel access based on target wake time mechanism in 802.11 ax WLANs. *IEEE Trans. Wirel. Commun.* **2020**, *20*, 1529–1543.
2. IEEE Standard for Information Technology–Telecommunications and Information Exchange between Systems Local and Metropolitan Area Networks–Specific Requirements Part 11: Wireless LAN Medium Access Control (MAC) and Physical Layer (PHY) Specifications Amendment 1: Enhancements for High-Efficiency WLAN. *IEEE Std 802.11ax-2021 (Amendment to IEEE Std 802.11-2020)* **2021**, 1–767.
3. Lee, K.-H. Performance analysis of the IEEE 802.11 ax MAC protocol for heterogeneous Wi-Fi networks in non-saturated conditions. *Sensors* **2019**, *19*, 1540.
4. Nurchis, M.; Bellalta, B. Target wake time: Scheduled access in IEEE 802.11 ax WLANs. *IEEE Wirel. Commun.* **2019**, *26*, 142–150.
5. Bankov, D.; Didenko, A.; Khorov, E.; Lyakhov, A. OFDMA uplink scheduling in IEEE 802.11 ax networks. In Proceedings of the IEEE International Conference on Communications (ICC), Kansas City, MO, USA, 20–24 May 2018.
6. Bankov, D.; Didenko, A.; Khorov, E.; Loginov, V.; Lyakhov, A. IEEE 802.11 ax uplink scheduler to minimize delay: A classic problem with new constraints. In Proceedings of the IEEE International Symposium on Personal, Indoor, and Mobile Radio Communications (PIMRC), Montreal, QC, Canada, 8–13 October 2017.
7. Ma, X.; Gao, Q.; Wang, J.; Marojevic, V.; Reed, J.H. Dynamic sounding for multi-user MIMO in wireless LANs. *IEEE Trans. Consum. Electron.* **2017**, *63*, 135–144.
8. Naik, G.; Bhattarai, S.; Park, J.-M. Performance analysis of uplink multi-user OFDMA in IEEE 802.11ax. In Proceedings of the IEEE International Conference on Communications (ICC), Kansas City, MO, USA, 20–24 May 2018.
9. Hoefel, R.P.F. IEEE 802.11 ax (Wi-Fi 6): DL and UL MU-MIMO channel sounding compression schemes impaired with IQ imbalance and CFO. In Proceedings of the IEEE Vehicular Technology Conference (VTC), Antwerp, Belgium, 25–28 May 2020.
10. Son, Y.; Kim, S.; Byeon, S.; Choi, S. Symbol timing synchronization for uplink multi-user transmission in IEEE 802.11 ax WLAN. *IEEE Access* **2018**, *6*, 72962–72977.
11. Bhattarai, S.; Naik, G.; Park, J.-M.J. Uplink resource allocation in IEEE 802.11ax. In Proceedings of the IEEE International Conference on Communications (ICC), Shanghai, China, 20–24 May 2019.
12. Lanante, L.; Ghosh, C.; Roy, S. Hybrid OFDMA random access with resource unit sensing for next-gen 802.11 ax WLANs. *IEEE Trans. Mob. Comput.* **2020**, doi:10.1109/TMC.2020.3000503.
13. Lee, K.-H. Using OFDMA for MU-MIMO user selection in 802.11 ax-based Wi-Fi networks. *IEEE Access* **2019**, *7*, 186041–186055.
14. Bellalta, B.; Kosek-Szott, K. AP-initiated multi-user transmissions in IEEE 802.11 ax WLANs. *Ad Hoc Netw.* **2019**, *85*, 145–159.

15. Kawamura, K.; Inoki, A.; Nakayama, S.; Wakao, K.; Takatori, Y. Cooperative control of 802.11 ax access parameters in high density wireless LAN systems. In Proceedings of the IEEE Wireless Communications and Networking Conference (WCNC), Marrakesh, Morocco, 15–18 April 2019.
16. Kotagiri, D.; Nihei, K.; Li, T. Multi-user distributed spectrum access method for 802.11 ax stations. In Proceedings of the International Conference on Computer Communications and Networks (ICCCN), Honolulu, HI, USA, 3–6 August 2020.
17. Fu, H.; Kim, D.I. Analysis of throughput and fairness with downlink scheduling in WCDMA networks. *IEEE Trans. Wirel. Commun.* **2006**, *5*, 2164–2174.
18. Checco, A.; Leith, D.J. Proportional fairness in 802.11 wireless LANs. *IEEE Commun. Lett.* **2011**, *15*, 807–809.
19. Shen, L.; Wang, T.; Wang, S. Proactive proportional fair: A novel scheduling algorithm based on future channel information in OFDMA systems. In Proceedings of the IEEE/CIC International Conference on Communications in China (ICCC), Changchun, China, 11–13 August 2019.
20. Budhiraja, I.; Kumar, N.; Tyagi, S. Deep reinforcement learning based proportional fair scheduling control scheme for underlay D2D communication. *IEEE Internet Things J.* **2021**, *8*, 3143–3156.
21. Kim, Y.; Kim, G.; Lee, J.; Choi, W. UL-MU transmissions in IEEE 802.11ax networks. In Proceedings of the IEEE International Conference on Consumer Electronics (ICCE), Las Vegas, NV, USA, 4–6 January 2020.
22. Khorov, E.; Kiryanov, A.; Lyakhov, A.; Bianchi, G. A tutorial on IEEE 802.11 ax high efficiency WLANs. *IEEE Commun. Surv. Tutorials* **2018**, *21*, 197–216.