

Article

SWOT-SOR Analysis of Activated Carbon-Based Technologies and O₃/UV Process as Polishing Treatments for Hospital Effluent

Vittoria Grillini, Paola Verlicchi * and Giacomo Zanni

Department of Engineering, University of Ferrara, 44122 Ferrara, Italy; vittoria.grillini@unife.it (V.G.); giacomo.zanni@unife.it (G.Z.)

* Correspondence: paola.verlicchi@unife.it

Citation: Grillini, V.; Verlicchi, P.; Zanni, G. SWOT-SOR Analysis of Activated Carbon-Based Technologies and O₃/UV Process as Polishing Treatments for Hospital Effluent. *Water* **2022**, *14*, 243. <https://doi.org/10.3390/w14020243>

Academic Editor: Ana Rita Lado Ribeiro

Received: 23 December 2021

Accepted: 13 January 2022

Published: 14 January 2022

Publisher's Note: MDPI stays neutral with regard to jurisdictional claims in published maps and institutional affiliations.



Copyright: © 2022 by the authors. Licensee MDPI, Basel, Switzerland. This article is an open access article distributed under the terms and conditions of the Creative Commons Attribution (CC BY) license (<http://creativecommons.org/licenses/by/4.0/>).

Abstract: The management and treatment of hospital wastewater are issues of great concern worldwide. Both in the case of a dedicated treatment or co-treatment with urban wastewater, hospital effluent is generally subjected to pre-treatments followed by a biological step. A polishing treatment is suggested to promote (and guarantee) the removal of micropollutants still present and to reduce the total pollutant load released. Activated carbon-based technologies and advanced oxidation processes have been widely investigated from technical and economic viewpoints and applied in many cases. In this study, the potential exploitation of these technologies for the polishing treatment of hospital effluent is investigated by combining a Strengths, Weaknesses, Opportunities and Threats (SWOT) analysis with a Strategic Orientation (SOR) analysis. This approach allows a coherent strategy to be extracted from the SWOT-SOR data, increasing the chances of success of each technology. It emerges that both technologies present relevant and sometimes similar strengths and can present opportunities. At the same time, activated carbon-based technologies are more likely to contain the main identified threats than O₃/UV technology. The study also finds that, for both technologies, further research and development could improve their potential applications in the treatment of hospital wastewater.

Keywords: hospital effluent polishing; activated carbon; ozonation-UV irradiation; SWOT-SOR analysis

1. Introduction

In recent years, the management and treatment of hospital wastewater (HWW) have been issues of increasing concern all over the world [1]. Research has mainly focused on the occurrence of a wider spectrum of micropollutants (MPs) (namely pharmaceuticals, hormones, diagnosis agents and disinfectants) in raw hospital effluent [2] and on the development of appropriate strategies for their removal (in a dedicated treatment or co-treatment with urban wastewater) [3–5]. The main aim of these studies was to control and reduce the (potential) environmental risks caused by MP residuals released into the receiving water body. The recent pandemic has also highlighted the need to guarantee efficient removal of microorganisms (bacteria and viruses) in wastewater treatment plants (WWTP) [6].

At the same time, at the EU level, increasing attention is being paid to antibiotic-resistant bacteria and antibiotic resistance genes, as well as to nanoparticles and microplastics, as they can occur and diffuse through the water cycle, mostly in ways that are not yet fully understood [7,8].

It is well known that the additional treatments able to remove MPs have to guarantee different removal mechanisms, as the behaviour of MPs depends on their chemical and physical characteristics [9], which are very different. End-of-pipe treatments or the

upgrading of existing WWTPs are two possible approaches that could improve the removal efficiencies of these pollutants [10,11].

Two studies [1,12] gave an overview of the worldwide treatment trains adopted for hospital effluents in full-scale plants or investigated them at the lab or pilot scale. In particular, [12] provides removal efficiencies for a great number of MPs by adopting primary, secondary and tertiary treatments. It emerges that the variability ranges are compound-specific, and sludge retention time is one of the most influencing factors. It was shown that a secondary treatment is necessary to remove carbonaceous compounds, but it is not able to guarantee a high removal of most of the investigated MPs. Thus, a further step is necessary to reduce their load, which is then released in the environment. The most appropriate treatment technology considered in the different countries was identified on the basis of the highest removal efficiencies observed for a selection of MPs (*target compounds*, such as carbamazepine, ciprofloxacin, hormones, etc.) during the investigations and/or capital expenditure (CAPEX) and operational and maintenance costs (OPEX) for the different options. The most frequently adopted technologies aiming at improving removal were advanced biological processes (membrane bioreactors (MBRs), equipped with ultrafiltration (UF) membranes), activated carbon (AC) filtration and adsorption, ozonation and advanced oxidation processes (AOPs), nanofiltration, and reverse osmosis [1,12,13].

Among them, specific attention has been paid to AC-based technologies and AOPs based on O₃/UV, and some applications demonstrate this fact in a full-scale plant [13]. In addition, the experiences and expertise achieved by the different actors involved in (hospital) WWTP design and management can be useful when selecting the most adequate technology, as they can provide suggestions related to the advantages and drawbacks of different technologies from different viewpoints.

Bearing this in mind, in the current study, the two technologies were analysed in order to evaluate how to exploit their specific abilities in the treatment of hospital effluent, limiting the attention to MPs and not to the microbial load (including antibiotic-resistant genes and bacteria), by identifying their strengths, weaknesses, opportunities and threats (SWOT analysis). This step was then combined with the Strategic ORientation analysis (SOR), aiming at measuring the capacity of the technologies under evaluation to grasp the opportunities and to limit the threats identified in the previous SWOT analysis. Different stakeholders (researchers, project engineers and WWTP management engineers) were involved in the two steps, so that their viewpoints and expertise could be considered, and they could guide the future implementation of the technologies by selecting the most relevant strengths, weaknesses, opportunities and threats and by analysing the interactions between the strengths/weaknesses and opportunities/threats. In this way a strategic orientation can be found to better exploit the two technologies and, at the same time, to suggest developments that could allow their further application.

2. Promising Technologies under Evaluation

The treatments subjected to the analysis were AC-based technologies and the advanced oxidation process by O₃/UV (Figure 1).

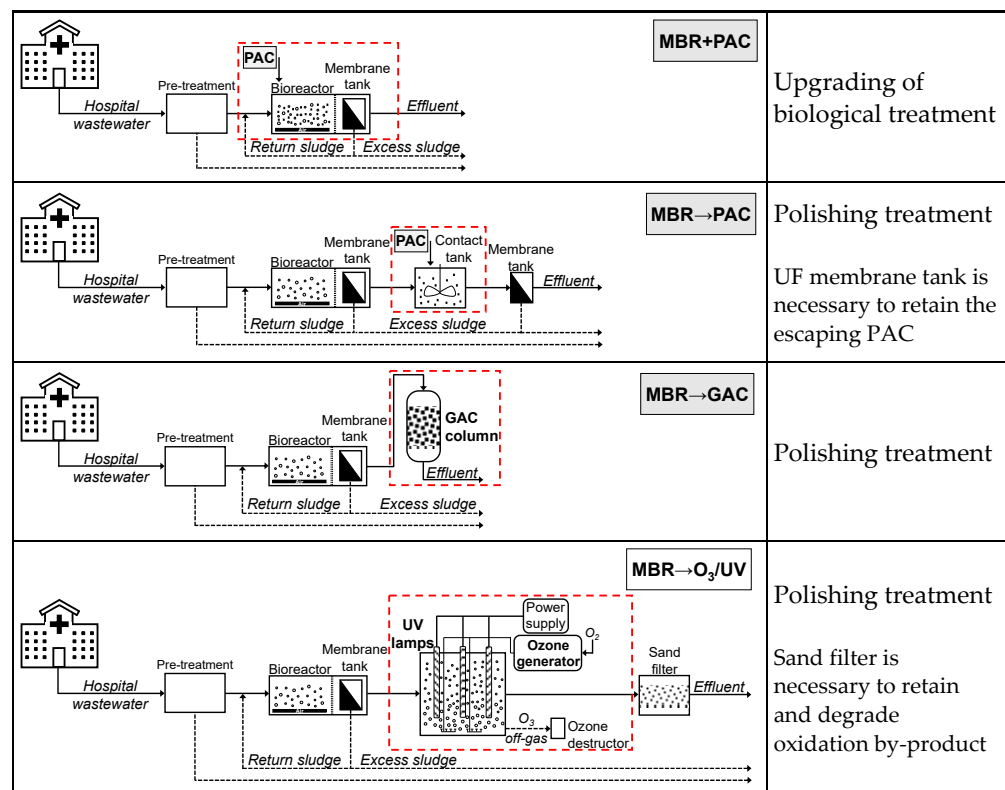

Figure 1. Typical configurations of a membrane bioreactor (MBR) combined with powdered (PAC) or granular (GAC) activated carbon and O₃/UV. The treatment steps under study are surrounded by red dotted lines.

Regarding AC, different applications were considered: (i) PAC added to the secondary treatment; (ii) PAC dispersed in a contact tank following the biological system; (iii) GAC dispersed in a column after the biological system. In the case of a PAC unit as a polishing treatment (case ii), a UF membrane filtration is necessary to prevent AC powder escaping with the effluent. Further details of the possible configurations are extensively reported in [14].

Regarding O₃/UV, it is placed after the activated sludge system and before a sand filter. The secondary treatment removes most of the biodegradable, dissolved and colloidal materials (reducing the demand for water oxidation), and the subsequent sand filter is able to retain and degrade the undesirable and unavoidable oxidation by-products, according to findings in the literature [13].

In the selected technologies, the ability to remove MPs from wastewater is due to the promotion of sorption mechanisms and biodegradation in the case of AC [10,15] and to chemical reactions due to direct ozonation, photolysis and reactions through radicals (indirect ozonation) in the case of O₃/UV [16,17]. Details of MP removal mechanisms and the main factors affecting them in the two different technologies are extensively discussed in [14].

The current study refers to the PAC contact unit, GAC column and O₃/UV reactor, which are the stages surrounded by red dotted lines in Figure 1. Other stages that may be required to complete the treatments, i.e., the UF membrane filtration or sand filtration in Figure 1, were not included in the analysis.

The selection of these technologies is due to the fact that they have been well studied for the removal of MPs in different kinds of wastewater, and many lessons can be learned from full, pilot and lab scale studies [10,11,18–20].

In the current study, it was assumed that the biological system consists of a membrane bioreactor (MBR). This is the solution suggested and adopted in the case of a dedicated treatment of HWW [2,12,13], but the analysis and considerations that follow can provide useful insights to understand what happens in the case of conventional activated sludge systems, where the liquid/solid separation after the biological reactor is achieved by a secondary clarifier and not by a membrane tank.

3. Applied Methodology

3.1. Introduction to the SWOT-SOR Analysis

The methodology used in this work is based on the succession of two complementary analytical techniques (SWOT and SOR analysis) which, when combined, allow the strategic planning of an “entity” to be set up (for example, a project, a firm, a technology, an economic sector, a local system, etc.).

Figure 2 shows the framework of the procedure, consisting of the two above-mentioned steps (SWOT and SOR analysis), which will be described in the following sections.

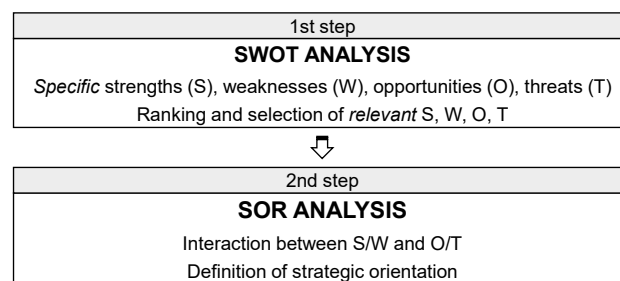

Figure 2. Framework of SWOT-SOR analysis.

3.1.1. First Step: SWOT Analysis

The *first step* is the SWOT analysis (also called the “design school model” by [21]). It is a decision support technique that includes the analysis of the four *categories*: strengths (S), weaknesses (W), opportunities (O) and threats (T), which leads to the identification of the corresponding relevant *factors* for each technology. Strengths and weaknesses form the *internal environment*, whereas opportunities and threats form the *external* one (see Table S1). These two environments make a distinction between controllable and uncontrollable factors.

Internal factors are the different characteristics of the analysed project (company, technology, etc.), which can be controlled by the decision makers (controllable factors). As an example, in the case of a technology, they may relate to technical performance, cost or environmental sustainability. Each characteristic can represent a strength or a weakness, depending on whether it promises to represent a winning or losing aspect in the competition with alternative projects.

External factors are those future events capable of influencing the project in a favourable or unfavourable way. It is not possible to directly intervene in them (uncontrollable factors), but they do need to be observed to exploit positive events and prevent negative ones. The external factors can be divided into the macro-environment and micro-environment. Macro-environment factors influence all human activities at large and correspond to political, economic, social, technological, environmental, legal and demographic factors; in contrast, micro-environment factors include factors in close contact with the project, such as existing competitors, new entrants, customers and suppliers [22,23].

The SWOT approach helps to carry out a useful qualitative investigation, especially if it leads to the identification of a *limited* number of truly relevant factors of the external

and internal environments. Methods for identifying internal and external factors range from the analysis of the literature from the sector to interviews of expert panels. Experts can be both members of the organization’s internal staff and external consultants. Interviews can be face-to-face or anonymous. Mixed methodologies can be adopted; the preparatory phase is based on previous experience and on the analysis of the available literature. This is followed by a free elaboration phase, carried out with interviews with experts (brainstorming type), to integrate the preparatory phase.

At the end of this phase, it is necessary to select the most relevant factors. In fact, if the number of factors resulting from the SWOT is high, the subsequent phase would become burdened with an excessive number of reports, and the planning work would risk being dispersed and of little effect. To avoid this, the list produced by the SWOT analysis is subjected to ranking and selection, as reported in Figure 2, which aims to reduce the number of factors of the four categories to the most relevant ones, indicatively, to four or five factors at most per category. The ranking can be defined in different ways, qualitatively and quantitatively.

3.1.2. Second Step: SOR Analysis

The final list of the most relevant strengths, weaknesses, opportunities and threats constitutes the basis of the *second step*, the SOR analysis. Its purpose is to analyse the relationships between internal and external factors, evaluating their specific relevance. This is generally carried out by means of a SOR matrix, which reports the external factors in columns and the internal factors in rows (see Table S2).

In general, this matrix allows the following four questions to be answered:

- (1) *To what extent do the strengths help to seize the opportunities?*
- (2) *To what extent do the strengths help to limit the threats?*
- (3) *To what extent do the weaknesses hinder the opportunities from being seized?*
- (4) *To what extent do the weaknesses hinder the threats from being limited?*

In particular, the matrix allows a cross-reading of the factors defined by the SWOT, in order to rigorously bring out the strategic priorities. The SOR Analysis is conducted in quantitative terms. At the intersection of each internal and external factor, a score is assigned between 0 and 3, on the basis of the importance of the aid or brake effect mentioned above. Table 1 shows how to conduct the analysis of the interactions and the criteria for the score assignment. It leads to the creation of a matrix split into four quadrants, one for each of the reported questions.

Table 1. Interactions between Strengths/Weaknesses and Opportunities/Threats and criteria for the assignment of the score (0, 1, 2, 3).

	Opportunities (O)	Threats (T)
	<i>Does the S help to seize the O?</i>	<i>Does the S help to limit the T?</i>
	0 → S does not relevantly help to seize O	0 → S does not relevantly help to limit T
Strengths (S)	1 → S slightly helps to seize O	1 → S slightly helps to limit T
	2 → S significantly helps to seize O	2 → S significantly helps to limit T
	3 → S helps to seize O to the greatest extent	3 → S helps to limit T to the greatest extent

	<i>Does the W hinder the O from being seized?</i>	<i>Does the W hinder the T from being limited?</i>
	0 → W does not relevantly hinder O from being seized	0 → W does not relevantly hinder T from being limited
WEAKNESSES (W)	1 → W slightly hinders O from being seized	1 → W slightly hinders T from being limited
	2 → W significantly hinders O from being seized	2 → W significantly hinders T from being limited
	3 → W hinders O from being seized to the greatest extent	3 → W hinders T from being limited to the greatest extent

The results of the SOR analysis are difficult to read if the scores are flattened upwards. To avoid this, specific limitations can be imposed, for example, not to exceed a maximum score for each row or column of the matrix, corresponding to the TOTAL (a + b) and DIFFERENCE (c - d) in Table S2 (the green and yellow cells, respectively). The scores can be entered vertically (by column, i.e., for each external factor) or horizontally (by row, i.e., for each internal factor).

Once completed, the SOR matrix requires an analysis from different viewpoints, as the resulting scores contain a set of relevant information that is useful for the strategic planning.

A first meaningful evaluation arises from the analysis of the distribution of scores within the four quadrants of the matrix; this will help to frame the right strategy. Schematically, the “pure” strategies that can be outlined are those shown in Table 2.

Table 2. Pure strategies for the different crossovers between the Strengths/Weaknesses and the Opportunities/Threats.

	Opportunities	Threats
Strengths	<i>Attack strategy</i>	<i>Defence strategy</i>
Weaknesses	<i>Change strategy</i>	<i>State of crisis</i>

With regard to Table S2, the prevalence of high scores in the S-O quadrant (top left), and in particular in cell H, indicates that the available strengths help to seize the existing opportunities. It is the most positive condition, as it is a promising prospect, founded on a secure base of resources. The strategy to be adopted is *attack*, aiming at strengthening the advantages already acquired. When the high scores fall in the S-T quadrant (top right), and in particular in cell I, this means that the available strengths limit the threats. The strategy to be embraced is of a *defensive* type, based on risk control, in order to minimize its impact. If high scores appear in the W-O quadrant (bottom left), and in particular in cell L, this means that the weaknesses limit the possibility of exploiting the existing opportunities. The situation is serious, as possible operational paralysis is foreseen. The strategy to be taken here is that of *change*. In other words, it is necessary to re-orientate the present condition, to allow greater use of the opportunities. Finally, the prevalence of high scores in the W-T quadrant (bottom right), and in particular in cell M, corresponds to the case in which the weaknesses hamper the possibility of containing the impending risks. This situation is, at least, as serious as the previous one, as it heralds a possible long-term state of *crisis*. To overcome it, a recovery strategy on the weaknesses is needed, which is capable of decreasing exposure to factors that threaten the system.

Another analysis is based on the sums of the scores of each row and each column, DIFFERENCE (c - d) and TOTAL (a + b) in Table S2, respectively. The first helps to highlight the most relevant external factors on which the development of the project focuses (the opportunities with the highest values and the threats with the lowest ones) and the major risks to be aware of (the opportunities with the lowest values and the threats with the highest ones). The highest values in TOTAL (a + b) correspond to the most

important strengths and weaknesses. These indications help the planner to identify the strategic priorities and useful measures to take greater advantage of when addressing the most relevant external factors.

Finally, a third evaluation refers to the score assigned to every single intersection between external and internal factors. The highest values provide the planner with useful insights into the strategic *objectives* to be developed.

3.2. SWOT-SOR Analysis Applied to the Specific Case

To develop the specific steps of the procedure outlined in Figure 2, different methodologies can be adopted. Those applied in the specific case study are presented here.

In particular, “Ranking and Selection” (second phase of the first step) and “Interactions between S/W and O/T” (first phase of the second step) were carried out using the opinions of external experts, who were interviewed using the Delphi method. Delphi is a structured group communication technique, originally developed as a method to systematically and interactively predict uncertain events. It is based on the principle that the judgment of a structured group is more accurate than that of an unstructured one [24]. In a structured group, each member is assigned a particular task to perform in order to achieve the group’s overall goal. In an unstructured group, a task is simply assigned, and each person is free to contribute as he/she so wishes.

The Delphi team in this study includes three experts (a researcher, a wastewater treatment plant managing engineer, and an environmental and sanitary engineer). The experts were interviewed independently. They answered the questionnaires iteratively. After each round, the facilitators (authors) provided a summary of the survey, based on the averages of the round scores. In this way, the experts were encouraged to review their previous responses in light of the responses of the rest of the group or after some clarifications they requested on the SWOT and SOR matrices. The iterative process was stopped based on a pre-defined criterion (stability of results and achievement of consensus).

With specific regard to ranking and selection, the interview was carried out with the support of the “pairwise comparison method”, according to the Analytic Hierarchy Process (AHP) approach [25]. The goal of the pairwise comparison was to measure the relative importance (priority) of the various factors identified within the four categories (S, W, O, T) and to reduce them to four factors per category. For each couple, experts were asked: “How much is factor A more important than factor B?”. The answers of each single interview were collected in a matrix similar to that of Table S3, in which all the factors were compared. Each judgment was quantified using a numerical scale measuring the “dominance” of one factor over the other. The coefficients indicate how many times the most important of the two factors dominates the least important factor. The scale of the coefficients ranged from 1 (which means “of equal importance”) to 9 (which means that the noted factor is “much (more) important” than the other). The collected values were then processed by the online web-based tool AHP-OS [26], which provided a table with the priority for each factor on an individual (expert) and global (whole panel) scale.

4. Results

Figure 3 reports the same framework as Figure 2, with the two steps split into the specific processes followed by the application of the SWOT-SOR analysis of the selected technologies.

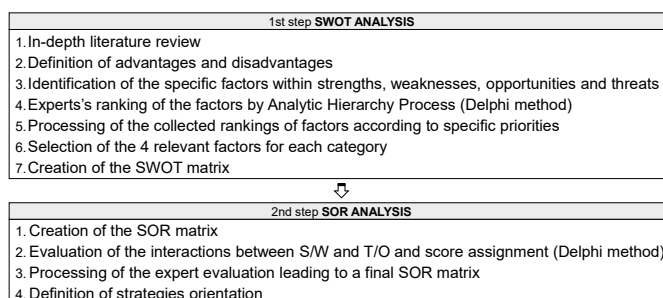

Figure 3. Framework of SWOT-SOR analysis applied to the selected technologies.

In the first step, an in-depth literature review was conducted to identify the main characteristics of AC and O₃/UV treatments, according to the configurations of Figure 1. The studies included in the survey had to refer to (hospital) effluent in terms of MP occurrence and/or treatment, mainly advanced wastewater treatments such as ozonation combined with UV radiation, or adsorption onto PAC (added in the bioreactor or in a contact tank, following the biological step) or GAC (in a dedicated column). Following a careful selection, conducted through SCOPUS, the initial collection of 50 peer-reviewed papers was reduced to 36 [1,2,10,14–17,19,27–54].

Advantages and drawbacks were first identified for each of the two technologies, and on this basis, it was possible to outline their main strengths, weaknesses, opportunities and threats. The results of this SWOT analysis are reported in Table S4 and Table S5. It emerged that there were 23 outline factors for AC and 21 for O₃/UV.

These two baselines were used to conduct the factor ranking and selection. To this end, the Delphi Group was involved with applying the AHP, as shown in the previous section. The three rankings obtained during the interviews provided homogeneous results. Therefore, they allowed the four most relevant factors to be identified for each SWOT category, both for the AC and O₃/UV technology (see Tables 3 and 4).

Table 3. SWOT matrix for AC technology.

Internal Factors	External Factors
<p>Strengths (S)</p> <p>S1 Water quality improvement</p> <p>S2 No by-product formation</p> <p>S3 Flexibility and availability of different configurations</p> <p>S4 Low energy consumption</p>	<p>Opportunities (O)</p> <p>O1 Customer request (of a promising and valuable (green) technology of low cost to be included in a dedicated treatment for hospital effluent)</p> <p>O2 National policies (implementation of national policies to reduce MPs in WWTP effluent)</p> <p>O3 EU Watch List *</p> <p>O4 Public interest in MP removal</p>
<p>Weaknesses (W)</p> <p>W1 Variability of AC performance</p> <p>W2 Waste production and disposal</p> <p>W3 Operational problems</p> <p>W4 High CAPEX and OPEX</p>	<p>Threats (T)</p> <p>T1 No specific regulation for the management and treatment of hospital effluent</p> <p>T2 Variation of MP concentration in hospital effluent</p> <p>T3 Attention to aquatic life</p> <p>T4 Other MP treatment technologies as its main competitors</p>

* In accordance with the European watch list [55], which is periodically updated (the last revision of the list refers to [56]).

Table 4. SWOT matrix for O₃/UV technology.

Internal Factors	External Factors
<p>Strengths (S)</p> <p>S1 Water quality improvement</p> <p>S2 Potential inhibition of by-product formation</p> <p>S3 No waste production</p> <p>S4 Small footprint and volume required</p>	<p>Opportunities (O)</p> <p>O1 Customer request (of a promising and valuable (green) technology of low cost to be included in a dedicated treatment for hospital effluent)</p> <p>O2 National policies (implementation of national policies to reduce MPs in WWTP effluent)</p> <p>O3 EU Watch List</p> <p>O4 Public interest in MP removal</p>
<p>Weaknesses (W)</p> <p>W1 Variability of O₃/UV performance</p> <p>W2 High O₃ dose (high water demand)</p> <p>W3 Safety concerns</p> <p>W4 High CAPEX and OPEX</p>	<p>Threats (T)</p> <p>T1 No specific regulation for the management and treatment of hospital effluent</p> <p>T2 Variation of MP concentration in hospital effluent</p> <p>T3 Attention to aquatic life</p> <p>T4 Other MP treatment technologies as its main competitors</p>

The two SWOT matrices were used to set up the SOR matrices (Tables 5 and 6). As already mentioned, the Delphi method was employed, and the same experts interviewed in the ranking and selection phases were involved in the SOR analysis. They were interviewed more than once, with the task of analysing the interactions between each internal and external factor. At the end, all experts evaluated 64 combinations, assigning a score from 0 to 3 to each cell of the matrix, as reported in Section 3. According to the literature on this method [57,58], scores were assigned by column, as this mode allows the coherence of strengths (or weaknesses) to be judged in series with respect to each opportunity (or threat).

Table 5. SOR matrix for AC technology.

		Opportunities				Threats				Sub Total T (b)	Total (a + b)	
		O1 Customers request	O2 National policies	O3 EU watch list	O4 Public interest on MP removal	T1 No specific regulation	T2 Variation of MP concentration	T3 Attention to aquatic life	T4 Other MP treatment technologies			
Strengths	S1 Water quality improvement	2	3	3	3	11	1	1	2	1	5	16
	S2 No by-product formation	2	2	3	1	8	1	3	3	2	9	17
	S3 Flexibility and availability of different configurations	2	1	0	0	3	2	3	0	2	7	10
	S4 Low energy consumption	2	1	0	2	5	2	1	1	2	6	11
	Sub Total S (c)	8	7	6	6	27	6	8	6	7	27	54
Weaknesses	W1 Variability of AC performance	1	1	1	1	4	1	2	1	1	5	9
	W2 Waste production and disposal	2	1	1	2	6	2	2	1	2	7	13
	W3 Operational problems	1	0	0	0	1	2	1	0	1	4	5
	W4 High CAPEX and OPEX	3	0	0	1	4	3	2	0	1	6	10
	Sub Total W (d)	7	2	2	4	15	8	7	2	5	22	37
	Difference (c – d)	1	5	4	2	12	-2	1	4	2	5	17

Table 6. SOR matrix for O₃/UV technology.

		Opportunities					Threats				Sub Total O (a)	Sub Total T (b)	Total (a + b)
		O1 Customers request	O2 National policies	O3 EU watch list	O4 Public interest on MP removal	T1 No specific regulation	T2 Variation of MP concentration	T3 Attention to aquatic life	T4 Other MP treatment technologies				
Strengths	S1 Water quality improvement	2	3	3	3	11	1	1	2	1	5	16	
	S2 Potential inhibition of by-product formation	1	1	2	1	5	1	1	1	1	4	9	
	S3 No waste production	2	1	1	2	6	1	3	1	2	7	13	
	S4 Small footprint and volume required	2	1	0	0	3	2	0	0	2	4	7	
	Sub Total S (c)	7	6	6	6	25	5	5	4	6	20	45	
Weaknesses	W1 Variability of O ₃ /UV performance	2	2	2	1	7	2	2	1	2	7	14	
	W2 High O ₃ dose (high water demand)	1	0	1	0	2	2	2	1	2	7	9	
	W3 Safety concerns	1	2	0	1	4	2	1	0	2	5	9	
	W4 High CAPEX and OPEX	3	0	0	1	4	3	2	0	1	6	10	
	Sub Total W (d)	7	4	3	3	17	9	7	2	7	25	42	
	Difference (c – d)	0	2	3	3	8	-4	-2	2	-1	-5	3	

To avoid the phenomenon of “score flat upward”, the experts were asked to contain the total score assigned to each column to a maximum of 12, apart from particularly justified exceptions. The Delphi coordinators (the authors) elaborated a “resultant matrix” for each technology, by averaging the resulting data with the help of the notes taken during the interviews. The two resultant matrices were re-proposed to the experts in the Delphi second round, asking them if it was possible to converge on these. Their revised matrices were re-evaluated and shared again. At the end of this second round, all group members agreed with the SOR matrices corresponding to Tables 5 and 6.

5. Discussion

The analysis of the scores reported in the two SOR matrices (Tables 5 and 6) was carried out and, on this basis, the strategic implications for each of the two technologies were outlined in agreement with the experts involved in the analysis. The main features are discussed here.

5.1. AC Sorption/Filtration Technology

As to AC technology, it emerges that the most important strengths are no by-product formation (S2) and the high effectiveness in water quality improvement (S1). This results from the analysis of the values reported in the last column of Table 5 (17 and 16 in TOTAL (a + b)) corresponding to the sum of the scores assigned in evaluating how each strength is able to seize the opportunities and limit the threats. Both these strengths, S1 and S2, help to seize all the opportunities well and S2 (no by-product formation) limits the threats better than S1 does (Sub Totals T (b) are 9 and 5). Opportunity O3, EU Watch list, is well grasped by both strengths as well as the perspectives given by the development of national policies (O2); in contrast, public interest on MP removal is fully seized by S1 but not by S2. Regarding the threats, it emerges that S1 and S2 are well defended from the increasing concerns towards technologies that could threaten aquatic life (T3). S2 is also

able to fight the variability in MP concentrations in HWW (T2) and the competition due to treatment alternatives for MP removal (T4).

As to the weaknesses, the high production of exhausted AC (W2) and the High CAPEX and OPEX to implement this technology (W4) are those with the highest TOTAL (a + b) (14 and 10, respectively). W2 exposes AC technology to threats, mainly T1, T2 and T4 (the corresponding Sub Total T (b) is equal to 7). W4 prevents the opportunities offered by the market (O1) from being seized to the greatest extent and the absence of specific legal requirements (T1) from being limited.

The analysis by column (the scores in the row DIFFERENCE (c-d)) confirms that the best grasped opportunities are those of a legislative nature, both at the national level (O2) and at the European level (O3), whose total scores are +5 and +4, respectively. Regarding the threats, it emerges that the one against which AC technology defends itself in the worst way is T1 (the lack of a specific legal obligation for hospital effluent management and treatment), whose total score is equal to -2. On the other hand, the threat that this treatment is able to limit is T3 (the increasing concern towards technologies that could threaten aquatic life), whose total score is 4.

The quadrants with the highest density of high scores are S-0 and S-T, having the same score of 27 in cells corresponding to the positions H and I, according to Table S2. Instead, the score is 22 in the W-T quadrant (cell M according to Table S2) and 15 in the last quadrant W-O (cell L according to Table S2). This means that the strategy for AC technology success can be played both “*on offense*” and “*on defence*” in accordance with Table 2. In other words, AC technical characteristics seize the listed opportunities well and, at the same time, defend themselves well against possible external threats. AC, in powder or in grains, acts as a trap for a wide spectrum of MPs, and its sorption potential is not affected by variations in their feeding concentrations. MPs are retained and maintain their characteristics, without being involved in chemical reactions that could generate other MPs (transformation products) of different chemical and, above all, ecotoxicological characteristics. This typical removal mechanism meets the market demands to reduce overall pollutant content and also the constraints related to existing and ongoing national and European legislation on MP reduction in the treated effluent. Different types of AC are available, and not all of them are present the same aptitude in removing MPs; those that better fit the aim to reduce MPs from wastewater are of a higher quality and are more expensive. Once they are exhausted and regeneration (in the case of GAC) is not sufficient, they are destined to be replaced by a virgin one. Until efficient regeneration techniques have been developed with sustainable costs and the regenerated AC can be reused, disposal costs cannot be reduced.

The “absolute” performance of AC technology is measured by the bottom right resulting value, which is 17 (cell Q in Table S2). This value derives from the difference between the sum of the total score of the rows referring to strengths ($N = 54$ in Table S2) and the sum of the total score referring to weaknesses ($P = 37$ in Table S2). This score, compared with the theoretical maximum value, equal to 96 (i.e., the extreme case in which all the strengths reached the top score equal to 3 and all weaknesses were null), highlights that the weaknesses seem to be less relevant than the strengths, but they are not negligible.

From a strategic perspective, the chances of AC technology can be improved by maintaining, on the one hand, high strengths and, above all, on the other, by promoting interventions on the most critical weaknesses. For example, the adoption of AC will be facilitated if progress in research and development is able to reduce the costs of disposing of exhausted AC (W2) and if other expenditure, investment and operational items (W4) are able to be reduced. High costs for AC generation could be reduced if the use of more economic raw materials (such as biomass, biochar, etc.) could lead to the production of AC in grains or powder with the same sorption capacity as coal carbon and of the same durability (lifespan). Currently, this is not the case.

5.2. O₃/UV Technology

The analysis of the O₃/UV technology SOR matrix (Table 6) presents similarities and differences regarding the analysis of AC technology.

With regard to the strengths, the highest score is found for S1 (Water quality improvement, similarly to AC technology) and S3 (No waste production), with the corresponding TOTALS (a + b) of 16 and 13, respectively. As to AC technology, the performance of O₃/UV regarding water quality improvement (S1) grasps the whole set of opportunities well (the corresponding Sub Total O (a) is 11). S3 makes this treatment particularly suitable for hospital effluent applications, characterised by an expected variability of MP concentrations (T2) over time.

The weakest point of this technology is the variability of the O₃/UV performance (W1, the corresponding TOTAL (a + b) is 14). On the one hand, W1 is an obstacle in grasping the opportunity offered by the market (O1) and by the public regulations at a national (O2) and European level (O3). On the other hand, W1 increases exposure to three (T1, T2 and T4) out of the four outlined threats. For instance, the instability of performance (W1) appears to be an unfavourable factor in the face of the risks that the MP concentration variability of hospital effluents (T2) entails.

The second most critical weakness is the high CAPEX and OPEX (W4), with a TOTAL (a + b) of 10. The high cost issue is also present in AC technology (the same TOTAL (a + b) values). In both cases, it hinders the opportunities offered by the market (O1) from being seized to the greatest extent and the absence of specific legal requirements (T1) from being defended.

An analysis of the data by column (DIFFERENCE (c - d)) shows that the opportunities related to legislative (O2, O3) and social (O4) fields present very similar overall scores (2, 3 and 3, respectively) and are more important than those related to the free market (O1, whose overall score is equal to 0). On the contrary, regarding the threats, the most worrying is the absence of a specific legal obligation (T1, whose overall score is 4).

The scores are spread over the four quadrants more evenly than that found for AC technology. This implies two difficulties: on the one hand, it shows that the chances of success of the strategy under study are limited, as the weak points are able to frustrate the impact of the positive factors; on the other hand, they hinder the identification of a clear and coherent strategy. O₃/UV technology is able to improve the water quality, but very high doses are necessary if the feeding becomes worse, with a higher number of pollutants. In fact, ozone and radicals generated by the AOP mostly react with macropollutants rather than with MPs. As a result, the treatment may lead to less removal of the desired MPs. An increment in the applied dose of ozone and UV means a relevant increment in the operational cost and also a potential increment in undesired by-products, which could generate a final effluent that is more toxic than expected.

As to the absolute performance of this technology, it emerges that the score at the bottom right (Q in Table S2) is equal to 3, much lower than that for AC technology (equal to 17, see Table 5). This means that the strengths almost offset the weaknesses; the total score of the rows relating to the strengths ($N = 45$ in Table S2) is slightly higher than that of the weaknesses ($P = 42$ in Table S2). It can be said that the strengths positively capture the opportunities offered by the external context, and they provide sufficient protection against the outlined threats. However, at the same time, the weaknesses of the technology undermine the chances of success, more or less to the same extent.

On the basis of this analysis, the strategy for the O₃/UV technology is more uncertain and more difficult to be implemented than the AC technology strategy. It is, above all, a question of removing most of the technical and economic obstacles that currently hinder its wider application. Among the most critical ones are facing the problem of the variability of technological performance, lowering investment and management costs and reducing safety issues.

6. Conclusions and Future Research

From the SWOT analysis of the two selected technologies and the discussion of possible strategic actions (SOR analysis) for their wider implementation, it emerged that both technologies have relevant strengths, but also some non-negligible weaknesses. The extrapolated strategies have several points in common. The O₃/UV technology shows some weaknesses, which do not appear to be adequately compensated by the strengths. This does not mean that this technology is not likely to be adopted as a polishing treatment for hospital effluent, but that, if specific actions are implemented, some weaknesses of this technology can be mitigated, consequently making some threats less important. For instance, due to the high ozone and generated radical reactivity with the organic matter of ozone (and of generated radicals), an increment in the organic matter concentration in the water under treatment implies a higher ozone demand, thus a higher ozone dose to be added for the removal of MPs and a potential increment in the resulting toxicity. If reliable pre-treatments were present and able to maintain a constant concentration of organic matter in the O₃/UV feeding step, the whole treatment system would be able to perform better, and the step would not be characterised by weakness W2 (High O₃ dose) and, at the same time, would better defend itself from threat T3 (Attention to aquatic life).

Common points between the two technologies concern market attractiveness (O1) and the lack of specific legal requirements for hospital effluent management and treatment (T1). The results indicate that, for both technologies, although O1 is a potentially relevant opportunity as favoured by the positive performance, it is weakened by the awareness of some weaknesses that hinder its market attractiveness, especially the high cost of technology implementation. Regarding threat T1, the weaknesses of the two technologies contribute to reducing the modest defence capacity of their strengths from it.

As regards the future research agenda, we can indicate two aspects that are particularly worthy of attention: one from a technological point of view and one from a strictly methodological point of view.

If the investment and operational costs of both technologies could be reduced, exhausted activated carbon could be recovered, and in the case of O₃/UV, the adoption of reliable upstream treatments could guarantee a constant quality of the water to be fed to the O₃/UV step, and thus a constant dose of O₃ and UV can be defined and applied. Then, some weaknesses could have less influence on the technology performance, and the two analysed systems could have greater market attractiveness.

With regard to the SWOT-SOR methodology, the current study shows that the most relevant step is the interpretation of the SOR matrix results. It is fundamental to carry out a complete overview of the possible options in order to extract the priority strategic objectives. To this end, the multi-stage iterative approach, adopted here, appeared particularly promising, and the study showed that if the experts of the panel have more time to reflect and to benefit from a more in-depth discussion, their replies can delve into the specific issues.

Finally, it is important to note that the methodology described herein can be applied to other technologies that are able to polish hospital effluent (such as ozonation, catalytic ozonation, nanofiltration, etc.) and also extended to the reduction of the microbial load (including antibiotic-resistant genes and bacteria, which have recently raised great concern among the scientific community). It is reasonable to think that internal factors (Strengths and Weaknesses) should be thoroughly investigated, as they are strictly related to the technology under evaluation, whereas, for the external ones (Opportunities and Weaknesses), some differences can be expected, but they are not as relevant as the internal ones.

Supplementary Materials: The following are available online at <https://www.mdpi.com/article/10.3390/w14020243/s1>, Table S1: SWOT matrix model; Table S2: SOR matrix model; Table S3: An example of AHP application; Table S4: Strengths, weaknesses,

opportunities, threats for AC treatment; Table S5: Strengths, weaknesses, opportunities, threats for O₃/UV treatment.

Author Contributions: Conceptualization, G.Z., P.V.; methodology, G.Z.; investigation, V.G.; data curation, V.G., P.V., G.Z.; writing—original draft preparation, V.G., P.V., G.Z.; writing—review and editing, V.G., P.V., G.Z.; supervision, G.Z., P.V.; funding acquisition, G.Z. All authors have read and agreed to the published version of the manuscript.

Funding: This research was funded by University of Ferrara Funds.

Conflicts of Interest: The authors declare no conflict of interest.

Abbreviations

AC: activated carbon; AOPs: advanced oxidation processes; CAPEX: capital expenditures; GAC: granular activated carbon; HWW: hospital wastewater; MBR: membrane bioreactor; MPs: micropollutants; O₃/UV: ozone-ultraviolet radiation; OPEX: operational expenditures; PAC: powdered activated carbon; SOR: Strategic ORientation; SWOT: strengths, weaknesses, opportunities and threats; UF: ultrafiltration; WWTP: wastewater treatment plant.

References

- Verlicchi, P. Trends, new insights and perspectives in the treatment of hospital effluents. *Curr. Opin. Environ. Sci. Health* **2021**, *19*, 100217. <https://doi.org/10.1016/j.coesh.2020.10.005>.
- Verlicchi, P.; Galletti, A.; Petrovic, M.; Barceló, D. Hospital effluents as a source of emerging pollutants: An overview of micropollutants and sustainable treatment options. *J. Hydrol.* **2010**, *389*, 416–428. <https://doi.org/10.1016/j.jhydrol.2010.06.005>.
- Rodriguez-Mozaz, S.; Lucas, D.; Barceló, D. Full-Scale Plants for Dedicated Treatment of Hospital Effluents. In *Hospital Wastewaters. Characteristics, Management, Treatment and Environmental Risks. Hdb Environm.Chemistry*; Verlicchi, P., Ed.; Springer: Cham, Switzerland, 2018; Volume 60, pp. 189–208, ISBN 978–3–319–62177–7.
- Verlicchi, P.; Galletti, A.; Al Aukidy, M. Hospital Wastewaters: Quali-Quantitative Characterization and for Strategies for Their Treatment and Disposal. In *Wastewater Reuse and Management*; Sharma, S., Sanghi, R., Eds.; Springer: Dordrecht, The Netherlands, 2013; pp. 225–251, ISBN 978–94–007–4941–2.
- Wiest, L.; Chonova, T.; Bergé, A.; Baudot, R.; Bessueille-Barbier, F.; Ayouni-Derouiche, L.; Vulliet, E. Two-year survey of specific hospital wastewater treatment and its impact on pharmaceutical discharges. *Environ. Sci. Pollut. Res.* **2018**, *25*, 9207–9218. <https://doi.org/10.1007/s11356-017-9662-5>.
- Zhang, T.; Xu, Q.; Shi, Y.-L.; Chen, Z.; Lu, Y.; Yang, H.-W.; Xie, Y.F.; Hou, L. Study on the influence of operational and management processes of a water reclamation plant since COVID-19 situation. *Environ. Pollut.* **2021**, *285*, 117257. <https://doi.org/10.1016/j.envpol.2021.117257>.
- COM/2019/128 Final Communication from the Commission to the European Parliament, the Council and the European Economic and Social Committee European Union Strategic Approach to Pharmaceuticals in the Environment. Available online: <https://eur-lex.europa.eu/legal-content/EN/TXT/PDF/?uri=CELEX:52019DC0128&from=EN> (accessed on 21 December 2021).
- Graça, C.A.L.; Ribeirinho-Soares, S.; Abreu-Silva, J.; Ramos, I.I.; Ribeiro, A.R.; Castro-Silva, S.M.; Segundo, M.A.; Manaia, C.M.; Nunes, O.C.; Silva, A.M.T. A Pilot Study Combining Ultrafiltration with Ozonation for the Treatment of Secondary Urban Wastewater: Organic Micropollutants, Microbial Load and Biological Effects. *Water* **2020**, *12*, 3458. <https://doi.org/10.3390/w12123458>.
- Rogers, H.R. Sources, behaviour and fate of organic contaminants during sewage treatment and in sewage sludges. *Sci. Total Environ.* **1996**, *185*, 3–26. <https://doi.org/10.1016/0048-969705039-5>.
- Rizzo, L.; Malato, S.; Antakyali, D.; Beretsou, V.G.; Đolić, M.B.; Gernjak, W.; Heath, E.; Ivancev-Tumbas, I.; Karaolia, P.; Lado Ribeiro, A.R.; et al. Consolidated vs new advanced treatment methods for the removal of contaminants of emerging concern from urban wastewater. *Sci. Total Environ.* **2019**, *655*, 986–1008. <https://doi.org/10.1016/j.scitotenv.2018.11.265>.
- Rizzo, L.; Gernjak, W.; Krzeminski, P.; Malato, S.; McArdell, C.S.; Perez, J.A.S.; Schaar, H.; Fatta-Kassinos, D. Best available technologies and treatment trains to address current challenges in urban wastewater reuse for irrigation of crops in EU countries. *Sci. Total Environ.* **2020**, *710*, 136312. <https://doi.org/10.1016/j.scitotenv.2019.136312>.
- Verlicchi, P.; Al Aukidy, M.; Zambello, E. What have we learned from worldwide experiences on the management and treatment of hospital effluent?—An overview and a discussion on perspectives. *Sci. Total Environ.* **2015**, *514*, 467–491. <https://doi.org/10.1016/j.scitotenv.2015.02.020>.
- Pills Report Pharmaceutical Residues in the Aquatic System—A Challenge for the Future. Insights and Activities of the European Cooperation Project PILLS. Available online: http://www.pills-project.eu/PILLS_summary_english.pdf (accessed on 21 December 2021).
- Metcalf & Eddy 6–8 Advanced oxidation and 11–9 Adsorption. In *Wastewater Engineering: Treatment and Resource Recovery*; McGraw-Hill Education: New York, NY, USA, 2014; pp. 510–521, 1224–1245, ISBN 9781259010798.

15. Gutiérrez, M.; Grillini, V.; Mutavdžić Pavlović, D.; Verlicchi, P. Activated carbon coupled with advanced biological wastewater treatment: A review of the enhancement in micropollutant removal. *Sci. Total Environ.* **2021**, *790*, 148050. <https://doi.org/10.1016/j.scitotenv.2021.148050>.
16. Litter, M.; Quici, N. Photochemical Advanced Oxidation Processes for Water and Wastewater Treatment. *Recent Pat. Eng.* **2010**, *4*, 217–241. <https://doi.org/10.2174/187221210794578574>.
17. Rekhate, C.V.; Srivastava, J.K. Recent advances in ozone-based advanced oxidation processes for treatment of wastewater- A review. *Chem. Eng. J. Adv.* **2020**, *3*, 100031. <https://doi.org/10.1016/j.ceja.2020.100031>.
18. Kase, R.; Eggen, R.I.L.; Junghans, M.; Götz, C.; Hollender, J. Assessment of micropollutants from municipal wastewater Combination of exposure and ecotoxicological effect data for Switzerland. In *Waste Water Evaluation and Management*; García Einschlag, F.S., Ed.; InTech: Rijeka, Croatia, 2011; pp. 1–26, ISBN 978–953–307–233–3.
19. Sgroi, M.; Snyder, S.A.; Roccaro, P. Comparison of AOPs at pilot scale: Energy costs for micro-pollutants oxidation, disinfection by-products formation and pathogens inactivation. *Chemosphere* **2021**, *273*, 128527. <https://doi.org/10.1016/j.chemosphere.2020.128527>.
20. Verlicchi, P.; Galletti, A.; Masotti, L. Management of hospital wastewaters: The case of the effluent of a large hospital situated in a small town. *Water Sci. Technol.* **2010**, *61*, 2507–2519. <https://doi.org/10.2166/wst.2010.138>.
21. Mintzberg, H. *The Rise and Fall of Strategic Planning: Reconceiving Roles for Planning, Plans, Planners*; Free Press: New York, NY, USA, 1994; ISBN 9780029216057.
22. Porter, M. *Competitive Strategy: Techniques for Analyzing Industries and Competitors*; Free Press: New York, NY, USA, 1980; ISBN 9780029253601.
23. Armstrong, M. *A Handbook of Human Resource Management Practice*, 10th ed.; Kogan Page: London, UK, 2006; ISBN 9780749446314.
24. Rowe, G.; Wright, G. Expert Opinions in Forecasting: The Role of the Delphi Technique. In *Principles of Forecasting. International Series in Operations Research & Management Science*; Armstrong, J.S., Ed.; Kluwer Academic Publishers: Boston, MA, USA, 2001; pp. 125–144, ISBN 978–0-306–47630–3.
25. Saaty, T.L. *The Analytic Hierarchy Process: Planning, Priority Setting, Resource Allocation*; McGraw-Hill Education: London, UK, 1980, ISBN 9780070543713.
26. Goepel, K. Implementation of an Online software tool for the Analytic Hierarchy Process (AHP-OS). *Int. J. Anal. Hierarchy Process* **2018**, *10*, 469–487. <https://doi.org/10.13033/ijahp.v10i3.590>.
27. Chonova, T.; Labanowski, J.; Bouchez, A. Contribution of Hospital Effluents to the Load of Micropollutants in WWTP Influent. In *Hospital Wastewaters*; Verlicchi P. Ed.; Springer International Publishing: Cham, Switzerland, 2017; Volume 60, pp. 135–152.
28. Chonova, T.; Keck, F.; Labanowski, J.; Montuelle, B.; Rimet, F.; Bouchez, A. Separate treatment of hospital and urban wastewaters: A real scale comparison of effluents and their effect on microbial communities. *Sci. Total Environ.* **2016**, *542*, 965–975. <https://doi.org/10.1016/j.scitotenv.2015.10.161>.
29. Dhangar, K.; Kumar, M. Tricks and tracks in removal of emerging contaminants from the wastewater through hybrid treatment systems: A review. *Sci. Total Environ.* **2020**, *738*, 140320. <https://doi.org/10.1016/j.scitotenv.2020.140320>.
30. Eggen, T.; Vogelsang, C. Occurrence and Fate of Pharmaceuticals and Personal Care Products in Wastewater. In *Comprehensive Analytical Chemistry*; Elsevier: Amsterdam, The Netherlands, 2015; Volume 67, pp. 245–294, ISBN 9780444632999.
31. Ekblad, M.; Juárez, R.; Falås, P.; Bester, K.; Hagman, M.; Cimbritz, M. Influence of operational conditions and wastewater properties on the removal of organic micropollutants through ozonation. *J. Environ. Manag.* **2021**, *286*, 112205. <https://doi.org/10.1016/j.jenvman.2021.112205>.
32. Gawel, E.; Bedtke, N. Economic Requirements and Instruments for Sustainable Urban Water Management—Comparative Review. In *Urban Water Management for Future Cities*; Köster, S., Reese, M., Zuo, J., Eds.; Springer International Publishing: Berlin/Heidelberg, Germany, 2019; pp. 445–458, ISBN 9783030014889.
33. Hrkal, Z.; Harstadt, K.; Rozman, D.; Těšitel, J.; Kušová, D.; Novotná, E.; Váňa, M. Socio-economic impacts of the pharmaceuticals detection and activated carbon treatment technology in water management—an example from the Czech Republic. *Water Environ. J.* **2019**, *33*, 67–76. <https://doi.org/10.1111/wej.12370>.
34. Igos, E.; Mailler, R.; Guillosoy, R.; Rocher, V.; Gasperi, J. Life cycle assessment of powder and micro-grain activated carbon in a fluidized bed to remove micropollutants from wastewater and their comparison with ozonation. *J. Clean. Prod.* **2021**, *287*, 125067. <https://doi.org/10.1016/j.jclepro.2020.125067>.
35. Joseph, B.; Kaetzl, K.; Hensgen, F.; Schäfer, B.; Wachendorf, M. Sustainability assessment of activated carbon from residual biomass used for micropollutant removal at a full-scale wastewater treatment plant. *Environ. Res. Lett.* **2020**, *15*. <https://doi.org/10.1088/1748-9326/ab8330>.
36. Joshi, R.; Ratpukdi, T.; Knutson, K.; Bhatnagar, A.; Khan, E. Bromate formation control by enhanced ozonation: A critical review. *Crit. Rev. Environ. Sci. Technol.* **2020**, 1–46. <https://doi.org/10.1080/10643389.2020.1850169>.
37. Joss, A.; Siegrist, H.; Ternes, T.A. Are we about to upgrade wastewater treatment for removing organic micropollutants? *Water Sci. Technol.* **2008**, *57*, 251–255. <https://doi.org/10.2166/wst.2008.825>.
38. Kim, I.; Tanaka, H. Energy Consumption for PPCPs Removal by O₃ and O₃/UV. *Ozone Sci. Eng.* **2011**, *33*, 150–157. <https://doi.org/10.1080/01919512.2011.549427>.
39. Kim, I.; Tanaka, H. Use of Ozone-Based Processes for the Removal of Pharmaceuticals Detected in a Wastewater Treatment Plant. *Water Environ. Res.* **2010**, *82*, 294–301. <https://doi.org/10.2175/106143009X12487095236630>.

40. Kovalova, L.; Siegrist, H.; von Gunten, U.; Eugster, J.; Hagenbuch, M.; Wittmer, A.; Moser, R.; McArdell, C.S. Elimination of Micropollutants during Post-Treatment of Hospital Wastewater with Powdered Activated Carbon, Ozone, and UV. *Environ. Sci. Technol.* **2013**, *47*, 7899–7908. <https://doi.org/10.1021/es400708w>.
41. Logar, I.; Brouwer, R.; Maurer, M.; Ort, C. Cost-benefit analysis of the Swiss national policy on reducing micropollutants in treated wastewater. *Environ. Sci. Technol.* **2014**, *48*, 12500–12508. <https://doi.org/10.1021/es502338j>.
42. Luo, Y.; Guo, W.; Ngo, H.H.; Nghiem, L.D.; Hai, F.I.; Zhang, J.; Liang, S.; Wang, X.C. A review on the occurrence of micropollutants in the aquatic environment and their fate and removal during wastewater treatment. *Sci. Total Environ.* **2014**, *473–474*, 619–641. <https://doi.org/10.1016/j.scitotenv.2013.12.065>.
43. Lutterbeck, C.A.; Colares, G.S.; Dell’Osbel, N.; da Silva, F.P.; Kist, L.T.; Machado, Ê.L. Hospital laundry wastewaters: A review on treatment alternatives, life cycle assessment and prognosis scenarios. *J. Clean. Prod.* **2020**, *273*, 122851. <https://doi.org/10.1016/j.jclepro.2020.122851>.
44. Margot, J.; Kienle, C.; Magnet, A.; Weil, M.; Rossi, L.; de Alencastro, L.F.; Abegglen, C.; Thonney, D.; Chèvre, N.; Schäfer, M.; et al. Treatment of micropollutants in municipal wastewater: Ozone or powdered activated carbon? *Sci. Total Environ.* **2013**, *461–462*, 480–498. <https://doi.org/10.1016/j.scitotenv.2013.05.034>.
45. Mousel, D.; Palmowski, L.; Pinnekamp, J. Energy demand for elimination of organic micropollutants in municipal wastewater treatment plants. *Sci. Total Environ.* **2017**, *575*, 1139–1149. <https://doi.org/10.1016/j.scitotenv.2016.09.197>.
46. Paucar, N.E.; Kim, I.; Tanaka, H.; Sato, C. Effect of O₃ Dose on the O₃/UV Treatment Process for the Removal of Pharmaceuticals and Personal Care Products in Secondary Effluent. *ChemEngineering* **2019**, *3*, 53. <https://doi.org/10.3390/chemengineering3020053>.
47. Plakas, K.V.; Karabelas, A.J.; Georgiadis, A.A. Sustainability assessment of tertiary wastewater treatment technologies: A multi-criteria analysis. *Water Sci. Technol.* **2016**, *73*, 1532–1540. <https://doi.org/10.2166/wst.2015.630>.
48. Ruiz-Rosa, I.; García-Rodríguez, F.J.; Antonova, N. Developing a methodology to recover the cost of wastewater reuse: A proposal based on the polluter pays principle. *Util. Policy* **2020**, *65*, 101067. <https://doi.org/10.1016/j.jup.2020.101067>.
49. EPA Wastewater Technology Fact Sheet Granular Activated Carbon Adsorption and Regeneration. Available online: <https://nepis.epa.gov/Exe/ZyNET.exe/P1001QTK.TXT?ZyActionD=ZyDocument&Client=EPA&Index=2000+Thru+2005&Docs=&Query=&Time=&EndTime=&SearchMethod=1&TocRestrict=n&Toc=&TocEntry=&QField=&QFieldYear=&QFieldMonth=&QFieldDay=&IntQFieldOp=0&ExtQFieldOp=0&XmlQuery=> (accessed on 21 December 2021).
50. EPA Granular Activated Carbon Systems. Problems and Remedies. Available online: <https://nepis.epa.gov/Exe/ZyNET.exe/200045IP.TXT?ZyActionD=ZyDocument&Client=EPA&Index=1981+Thru+1985&Docs=&Query=&Time=&EndTime=&SearchMethod=1&TocRestrict=n&Toc=&TocEntry=&QField=&QFieldYear=&QFieldMonth=&QFieldDay=&IntQFieldOp=0&ExtQFieldOp=0&XmlQuery=> (accessed on 21 December 2021).
51. Völker, J.; Stapf, M.; Miehe, U.; Wagner, M. Systematic Review of Toxicity Removal by Advanced Wastewater Treatment Technologies via Ozonation and Activated Carbon. *Environ. Sci. Technol.* **2019**, *53*, 7215–7233. <https://doi.org/10.1021/acs.est.9b00570>.
52. Zepon Tarpani, R.R.; Azapagic, A. Life cycle environmental impacts of advanced wastewater treatment techniques for removal of pharmaceuticals and personal care products (PPCPs). *J. Environ. Manag.* **2018**, *215*, 258–272. <https://doi.org/10.1016/j.jenvman.2018.03.047>.
53. Bui, X.T.; Vo, T.P.T.; Ngo, H.H.; Guo, W.S.; Nguyen, T.T. Multicriteria assessment of advanced treatment technologies for micropollutants removal at large-scale applications. *Sci. Total Environ.* **2016**, *563–564*, 1050–1067. <https://doi.org/10.1016/j.scitotenv.2016.04.191>.
54. Carraro, E.; Bonetta, S.; Bertino, C.; Lorenzi, E.; Bonetta, S.; Gilli, G. Hospital effluents management: Chemical, physical, microbiological risks and legislation in different countries. *J. Environ. Manag.* **2016**, *168*, 185–199. <https://doi.org/10.1016/j.jenvman.2015.11.021>.
55. European Commission Directive 2008/105/EC of the European Parliament and of the Council of 16 December 2008 on Environmental Quality Standards in the Field of Water Policy Amending and Subsequently Repealing Council Directives 82/176/EEC, 83/513/EEC, 84/156/EEC, 84/491/EEC. Available online: <https://eur-lex.europa.eu/legal-content/EN/TXT/?uri=celex%3A32008L0105> (accessed on 21 December 2021).
56. European Commission Commission Implementing Decision (EU) 2020/1161–4 August 2020-Establishing a Watch List of Substances for Union-Wide Monitoring in the Field of Water Policy Pursuant to Directive 2008/105/EC of the European Parliament and of the Council. Available online: https://eur-lex.europa.eu/legal-content/EN/TXT/?uri=uriserv:OJ.L_.2020.257.01.0032.01.ENG&toc=OJ:L:2020:257:TOC (accessed on 21 December 2021).
57. Vermeire, B.; Gellynck, X.; Bartoszek, P.; Rijswijk, L. *Strategic Objectives for Developing Innovation Clusters in the European Food Industry: Report of Overall SWOT Analysis and Strategic Orientation in the FINE Project*; Food Innovation Network Europe; Development Agency East Netherlands: Arnhem, The Netherlands, 2006.
58. MDF. *Tango for Organisations—40 Tools for Institutional Development and Organisational Strengthening*; MDF Training & Consultancy: Ede, The Netherlands, 2004; ISBN 9080868515.