

*EVS28*  
*KINTEX, Korea, May 3-6, 2015*

## **Preliminary Modular Design for Electric Personal Mobility with Design-Engineering Collaboration**

Hyunjune Yim<sup>1</sup>, Keun Lee<sup>2</sup>

<sup>1</sup>*Department of Mechanical & System Design Engineering / Personal Mobility Research Center, Hongik University, Seoul, Korea, hjyim@hongik.ac.kr*

<sup>2</sup>*Department of Industrial Design / Personal Mobility Research Center, Hongik University, Seoul, Korea, kleeoh@empal.com*

---

### **Abstract**

Electrically powered personal mobility is expected to emerge as a new mode of transportation, in response to impending socioeconomic issues such as urbanization, global climate changes, demographic changes, and increasing number of single-person households. Yet, in the transition, the market for each usage of personal mobility such as passenger transportation, delivery of goods, assisting the less abled, or pastime recreation is not big enough for mass production of each model. This may preclude most enterprises from entering the market.

The paper presents a prospective, and realistic solution: modular design to produce a number of variant models based on a common platform, and further modularization of the platform itself, to achieve a high degree of the economies of size. It is shown that using this extended modular design strategy, three-wheeled vehicles with two front wheels or those with two rear wheels, for example, can be developed based on a common mid-portion of the platform. Such extensive modular design is relatively easy for electric personal mobility because of its small number of components, simple architecture, and easily separable groups of components.

Furthermore, the paper illustrates the collaborative roles of industrial designers (ID) and engineering designers (ED) in each step of the preliminary design process adopted here. Personal mobility designs developed in this work demonstrate the importance of such collaborative efforts; for example, engineering design for dynamic stability and package layout design affect each other, so clear communication and compromise between ID and ED is crucial. Overall, the paper sheds light on a prospective direction for electric personal mobility to become one of the major mobility means in the near future.

*Keywords: Personal mobility, Modular design, Design-engineering collaboration*

---

### **1 Introduction**

The concept and general form of present automobiles have been prevalent over a century

now. It is, however, anticipated that there will emerge various alternative transportation means in the near future, to cope with many challenges that humankind is facing today. Electric personal

mobility (defined here as micro-sized electric vehicles for one or two passengers) seems to be one of the most prospective alternatives in several respects below.

First of all, fast urbanization is under way around the world. In fact, the global population concentration rate in cities was 54% in 2014, but is projected to reach 66% by 2050 [1]. This will result in the lack of road capacity to accommodate the drastic increase of vehicles in urban areas. Therefore, significant size reduction of vehicles is called for.

The second obvious driver for electric personal mobility is the ever increasing pressure to reduce carbon footprint for coping with environmental issues such as the global climate changes. It is certain that smaller and lighter mobility will lead to reduced carbon footprints.

Thirdly, demand for personal mobility will also increase due to the already occurring global demographic change, often termed the 'ageing society'. The global population share of older people (aged 60 years or over) was 11.7% in 2013, but is expected to grow and reach 21.1% by 2050 [2]. In spite of the advancement of medical and biological technology, the elderly in general still suffer from a range of health problems including limited mobility. Personal mobility that can offer short-distance transportation to the elderly can alleviate the societal problems associated with the ageing society.

Finally, it is important to note that the needs for personal mobility are diverse. For example, personal mobility needed in rural areas may be different from that in urban areas in that it should enable the users, particularly the elderly, to safely maneuver on narrow, curvy, and uneven paths between rice paddies or grain fields.

In response to these projected demands, a few major automobile manufacturers have each developed working prototypes of personal mobility, but they hesitate to mass produce it and enter the market. This seems to be mainly because the size of the each segmented market is not yet big enough to invest huge amount of capital into the business. It is noteworthy that, as discussed above, there are diverse types of demand for personal mobility (e.g. urban, rural, commuting, sports, for elderly, etc.), which will sum up to create a sizeable market. Therefore, if various types of personal mobility can be built as variants of a base model using the modular design concept, it may be an effective means to overcome the economic challenge of risky

investment, through the shortened time to market and reduced production cost. This is indeed the platform strategy [3-7] that most automobile manufacturers have been using.

The present paper presents a preliminary design project in which the modular design strategy was extensively applied to personal mobility. In so doing, both industrial design and engineering design aspects have been collaboratively explored and integrated together.

In Section 2, modular design in general is discussed and how it is applied to personal mobility in this work is explained. Section 3 presents the design process adopted in this study and the outcomes for personal mobility. The details of modular designs developed in this study are exhibited in Section 4, followed by conclusions in Section 5.

## 2 Modular Design Strategy

The 'modular' design strategy in the field of product design may be divided into two categories: modularity in portfolio architecture of a company versus modularity in product architecture [8]. The following subsections discuss the relevant ideas based on [8], and specify the meaning of the term 'modular design' in this paper.

### 2.1 Modularity in portfolio architecture

Modularity in portfolio architecture is about shared components or subassemblies among products offered by a company, and it aims at satisfying a broad spectrum of market demands. The product portfolio architecture of a manufacturing firm may fall into three basic categories: fixed unsharing, modular platform, and massively customizable architecture [8].

Among these, the modular platform architecture is relevant in this paper. Here, 'platform' means the common components, modules or systems among the products in the portfolio, as the term has been used in the automotive industry [3-7]. All products supported by the same platform are called 'variants'.

There are at least five different types of modularity that may be seen in a modular platform architecture: modular product family, modular product generations, consumable modular platform, standard modular platform, and adjustable modular platform for purchase [8]. The modularity sought in the present paper is mostly the modular product family, which means that products in a portfolio share a platform at a given time.

## 2.2 Modularity in product architecture

In contrast, modularity in product architecture is about how to map the sub-functions of a single product to its components, thus affecting the physical form of the product [8]. A product may satisfy all of its sub-functions by being divided into smaller modules that each fulfils one or a few sub-functions, or not being divided at all. The latter case is called integral design.

By grouping and assigning sub-functions to separate modules, the product is enabled to reconfigure and fulfil multiple tasks through the replacement of the modules by different functioning modules. There are four types of this function-based modularity, depending on the nature of interface between the main part and modules or among the modules: slot modularity, bus modularity, sectional modularity, and mix modularity [8]. Most of these modularity types support modularity in portfolio architecture through their increased reconfigurability.

Modular design in this study falls into the type of slot modularity. Slot modularity is the term used when a main part has a slot or slots where different modules carrying different functions can be attached. An example of slot modularity is an electric screw driver that can accept driver tips of different sizes and shapes.

## 2.3 Strategy for personal mobility

The two categories of modularity explained in the preceding subsections are often synergistically related to each other. For example, if a single product is modularly designed in its product architecture, it is easy to build a portfolio of products around it by designing the alternative modules carrying different sub-functions.

The idea of modular design in this study for personal mobility starts with modularity in portfolio architecture, but is indeed embodied by designing the product architecture such that the modular portfolio architecture is supported. The type of product architecture developed in the present work is slot modularity, as will be explained in Section 4.

## 3 Collaborative Design Process

This section delineates the preliminary design process adopted in this study, and presents the outcomes obtained for personal mobility in each step of the process.

The design process consists of four steps, as listed in Table 1, along with the tasks marked to

be executed by industrial designer (ID) or engineering designer (ED). It is clear in Table 1 that most tasks are collaboratively carried out by ID and ED because they require differing views of both industrial and engineering designers.

Table 1: Collaborative design process between industrial designer (ID) and engineering designer (ED)

Step	Task	ID	ED
Conception	User definition	√	√
	Lifestyle and user scenario study	√	
	Design trend study	√	
	Technology trend study		√
	Benchmarking	√	√
Ideation	Concepts generation (2D sketches)	√	√
	Package layout	√	√
	Concept evaluation & selection	√	√
Development & Refinement	Digital 3D modelling	√	√
	Model verification (3D printout)	√	√
	Ergonomics check (mock-up)	√	√
	Package feasibility check (mock-up)	√	√
	Engineering analyses		√
Simulation	VR demonstration	√	
	Engineering simulation		√

### 3.1 Conception step

#### 3.1.1 Tasks

The first step of the design process is conception, which roughly consists of establishing the design goal and studying the context of the design problem. Design goal here means what will be designed for whom, whereas context means the trends in the lifestyle, technology, as well as the competitions in the target market.

As such, this conception step is essentially about problem definition, as is called in the engineering design process [9]. The most important outcome of the conception step is thus the target specifications to be satisfied by the design.

#### 3.1.2 Outcomes for personal mobility

As an outcome of this step, various target specifications have been set in the present study

for personal mobility, among which is the target dimensions of the vehicle. It was aimed to make each of the dimensions smaller than that of Renault Twizy™[10] or that of Toyota iRoad™[11], as shown in Table 2.

Table 2: Target dimensions in comparison with competitions [mm]

Dimension	Twizy™	iRoad™	Target
Length	2338	2350	≤2000
Width	1237	850	≤1200
Height	1454	1445	≤1400
Wheelbase	1686	1700	≤1500

### 3.2 Ideation step

#### 3.2.1 Tasks

The second step of the design process, termed ideation, starts with generating concepts that are expected to satisfy the specifications derived in the conception step. The concepts are typically generated in the form of sketches. In the present study, basic concepts of modular design are generated here.

Then, package layout is designed, where the components of the vehicle, such as the driver, seat, cargo space, electric motor, battery, inverter, converter, and so on, are positioned within the volume given by the sketched concepts. The final task in this step is the selection of one concept based on the evaluation of the many concepts generated above. In this evaluation, fundamental engineering analysis may be necessary to assess the engineering feasibility of the concepts.

#### 3.2.2 Outcomes for personal mobility

Examples of hand sketches produced in the early ideation phase of the present study are shown in Figure 1. Figure 2 illustrates one of the various concepts for modular design, which shows an idea of detachable external panels to generate body variants. Other modular design concepts, including three-wheeled mobility, were generated, but will be presented in Section 4.

Figure 3 shows how a package layout for vehicle body was designed using a computer tool, Siemens NX™, and digital human models at the 50<sup>th</sup> and 95<sup>th</sup> percentiles [12-14]. Many conceptual designs were evaluated and compared with each other from various aspects including the package layout. The finally selected conceptual design has dimensions listed in Table

3, and is compared with competitions in Figure 4. Note that all the dimensions in this conceptual design satisfy the target values duplicated from Table 2.



Figure 1: Free-hand sketches in early ideation

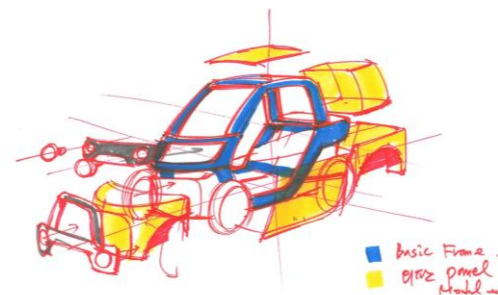

Figure 2: Idea sketch for modular design using detachable external panels for body

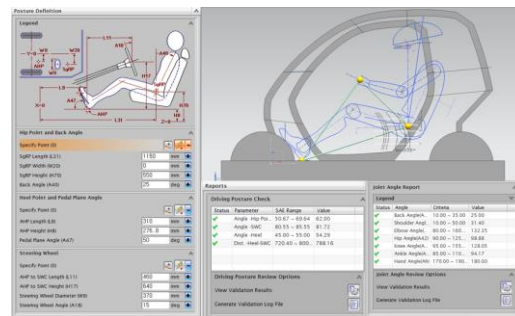

Figure 3: Package layout for vehicle body occupied by a driver (Siemens NX™)

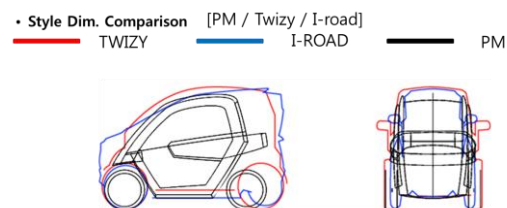

Figure 4: Dimensions of conceptual design in comparison with competitions

Table 3: Dimensions of conceptual design in comparison with target values [mm]

Dimension	Target	Conceptual design
Length	≤2000	2000
Width	≤1200	1160
Height	≤1400	1390
Wheelbase	≤1500	1500

### 3.3 Development and refinement step

#### 3.3.1 Tasks

The third step in the design process is to further develop and refine the conceptual design selected in the previous step. In this step, detailed digital model is developed using computer tools.

This detailed digital model is first verified by checking its 3D printout. Then, it is refined based on the detailed feasibility checks on package layout and ergonomics. Package feasibility may be checked digitally or physically by locating all components of the vehicle and the driver.

Ergonomics is usually examined by sitting the driver in the digital and physical mock-ups. This task is to make sure that the driver can clearly see around the vehicle as required for safe driving, and can easily manipulate all the controls inside the vehicle.

Engineering analyses are conducted in this step to ascertain that basic requirements for a vehicle, such as dynamic stability and structural integrity, are met. These analyses are usually done using computer-aided engineering (CAE) tools.

In this step, ID details such as colour, material and finishing (CMF) are also set, while being checked for aesthetics and semantics using real-time rendering tools.

#### 3.3.2 Outcomes for personal mobility

Figure 5 shows an intermediate phase of creating block surfaces during the ID digital modelling using Alias AutoStudio™. In parallel, ED digital models have also been developed and refined using Siemens NX™. Digital models for three-wheeled variants were also developed here at the same level of details.

Once all details had been modelled, the 3D model was used to generate 3D printing data as shown in Figure 6. Photographs of 3D-printed components and the complete assembly are shown in Figure 7. These 3D printouts were

thoroughly examined to verify the integrity of the 3D solid model.



Figure 5: Block surfacing in the process of 3D digital modelling, showing complete assembly and components (Alias AutoStudio™)



Figure 6: 3D printing data release



Figure 7: 3D-printed components and complete assembly



Figure 8: Ergonomics check using physical mock-up

For ergonomics check, a physical mock-up was built using wood and Styrofoam™, as in Figure 8. Attempts of various human motions inside the physical mock-up, mimicking typical activities of

a driver, uncovered a few ergonomic problems with the model: limited forward view, lack of leg room, and waste of side space. Reflecting these findings, the design was modified and refined, yielding new dimensions listed as ‘Ergo. model’ in Table 4. The length, height, and wheelbase in this revised model are greater than those in the conceptual design and exceed the “over-ambitious” target values, yet are comparable or smaller than those of the competitions.

Table 4: Modified dimensions based on physical ergonomic check, in comparison with conceptual design and target values [mm]

Dimension	Target	Conceptual design	Ergo. model
Length	$\leq 2000$	2000	2122
Width	$\leq 1200$	1160	1113
Height	$\leq 1400$	1390	1454
Wheelbase	$\leq 1500$	1500	1569

### 3.3.3 Engineering analysis on dynamic stability

A basic engineering analysis was conducted using CarSim™ [15] to validate the design in terms of the maneuver stability, i.e. stability against dynamic rollover. The purpose of this analysis was to assure dynamic stability of personal mobility, particularly the three-wheeled modular variants whose design will be presented in Section 4. There are two different types of three-wheeled models: delta type with two wheels in the rear, and tadpole type with two wheels in the front.

In this engineering analysis, the personal mobility models have been ‘driven’ in the CarSim™ simulation environment, according to the Fishhook Maneuver Test Procedure in New Car Assessment Program (NCAP) of U.S. National Highway Traffic Safety Administration (NHTSA) [16]. The dynamic maneuver stability is assessed in terms of the rollover critical velocity, over which the vehicle loses stability and cannot pass the Fishhook Procedure without rollover. This stability depends on many design parameters including the location of the center of gravity (CG) and suspension characteristics [17, 18].

As a result of this analysis, the four-wheeled base model with typical suspension parameters was found stable enough to exhibit a sufficiently high critical velocity. However, both delta and tadpole three-wheeled models, created with the same

dimensions as the base four-wheeled model, were found too unstable to be maneuvered at any practically useful velocity. This dynamic vulnerability of three-wheeled vehicles may be attributed to the relatively short horizontal distance between the CG and the rollover axis, which is the moment arm of the restoring moment in case of impending rollover; i.e.  $d < t/2$  in Figure 9 [17].

In order to assure dynamic stability of three-wheeled variants, the overall width of the vehicle had to be increased from 1113 mm to the target value of 1200 mm. All the other overall dimensions were not changed much and only adjusted to the close round numbers for the convenience of engineering analyses. At the same time as the width modification, the package layout was also redesigned using NX™ such that all major components, including the motor, inverter, battery, driver, and seat, would fit in the reduced triangular space. As a result of this package layout study, it was found that the CG may only be located within the following x-range as measured from the front axle:  $1097.7 \text{ mm} \leq x \leq 1207.9 \text{ mm}$  for the delta type, and  $723.5 \text{ mm} \leq x \leq 778.6 \text{ mm}$  for the tadpole type, as shown in Figure 10.

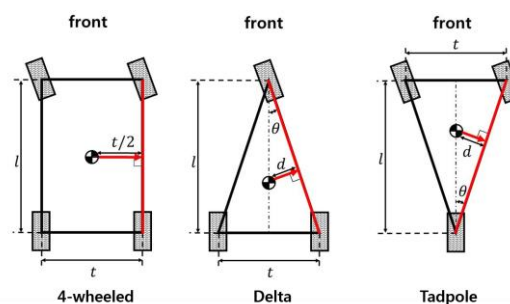

Figure 9: Important dimensions for rollover analysis of various models, with the rollover axis of rotation and restoring moment arm highlighted

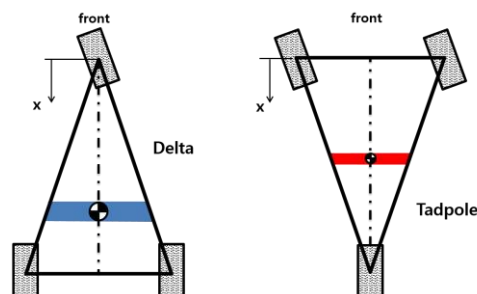

Figure 10: x-ranges of possible CG locations in delta and tadpole models, found by digital package layout study

Further simulation study using CarSim™ resulted in Figure 11 that shows the critical velocity for delta and tadpole models as the CG location is varied between the front and rear axles. The thick portions of the two curves are for the x-ranges of the possible CG location found above. Therefore, the thin portions of the curves do not have practical meaning but are shown to discuss a tendency below.

As can be seen in Figure 11, the delta model becomes more stable as the CG moves backward, i.e. towards the two-wheeled rear axle. The tadpole model shows a similar tendency of becoming more stable as the CG moves forward, i.e. towards the two-wheeled front axle, except for in the very vicinity of the front axle. This coherent tendency of the two models may be understood by considering Figure 9 again as the direction of increasing stability coincides with the direction of increasing moment arm of the restoring moment,  $d$ . A conclusion that can be drawn from the thick portions of the curves in Figure 11 is that the delta model is about 20% more stable than the tadpole model, in terms of the rollover critical velocity.

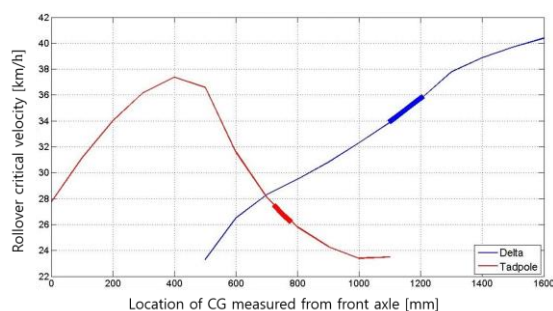

Figure 11: Rollover critical velocity versus CG location measured from front axle, for delta and tadpole models

### 3.4 Simulation step

#### 3.4.1 Tasks

In the final step of the design process, simulation is conducted using the digital models. A proper tool for ID simulation is virtual-reality (VR) simulation software, which can generate a video clip showing the vehicle running in pre-set landscapes. Engineering simulation of the vehicle may be done using the motion simulation functionality of CAD tools, dynamic simulation tools such as CarSim™, or structural analysis tools. These simulation outcomes may be used to effectively convey the design idea to the client or to the management.

#### 3.4.2 Outcomes for personal mobility

The personal mobility and their variants have been simulated using VR simulation software, Autodesk Showcase™. Figure 12 shows example snapshots of the VR simulation videos. Also, an example snapshot is shown in Figure 13 of the vehicle maneuvering simulation executed using CarSim™.



Figure 12: Example snapshots of VR simulation video featuring variants of personal mobility



Figure 13: Example snapshot of vehicle maneuvering simulation using CarSim™

## 4 Modular Design of Personal Mobility

As a main focus of this paper, modular design of personal mobility deserves a separate section. As such, this section will elaborate on the modular design strategy developed in the present study and the thus obtained results.

Modular design of personal mobility in this study is conducted in two directions: along the 'vertical' and 'horizontal' directions. As will be explained below in details, these two modular design strategies are respectively for the body variants and platform variants.

#### 4.1 Modular design in vertical direction

The term ‘vertical’ is associated with the positional relationship between the body and platform of personal mobility, as shown in the left of Figure 14. That is, this modularity means that the platform stays intact, and the body module varies. The right-hand image of Figure 14 shows how the body module can vary by assembling different sub-modules, as conceived in the hand sketch shown in Figure 2.

This product architecture falls in the category of slot modularity explained in Section 2, and supports the modular product family portfolio to satisfy various market needs. Figure 15 shows such examples with the four-wheeled platform.



Figure 14: Modular design in vertical direction (left) and sub-modules of the body (right)



Figure 15: Example variants from modular design in vertical direction

#### 4.2 Modular design in horizontal direction

Another aspect of modular design for personal mobility developed in this study is along the ‘horizontal’ direction. This is done by dividing the platform into three pieces: the front, middle, and rear, which are horizontally deployed with respect to each other. The middle piece serves as the ‘platform’ in this lower-level modular design, called sub-platform hereafter. And, the front and

rear pieces are now modules (called sub-modules hereafter) that can vary.

In the present study, the front and rear sub-modules may have one wheel or two wheels, resulting in four platform variants: four-wheeled, three-wheeled tadpole, three-wheeled delta, and two-wheeled models, as shown in Figure 16. Figure 17 shows the package layout design of the major electric components in case of four-wheeled platform. The locations of the electric motor and inverter must change as the number of wheels change among the variants in Figure 16, but the battery and converter always stay in the middle sub-platform, i.e. the battery pack.

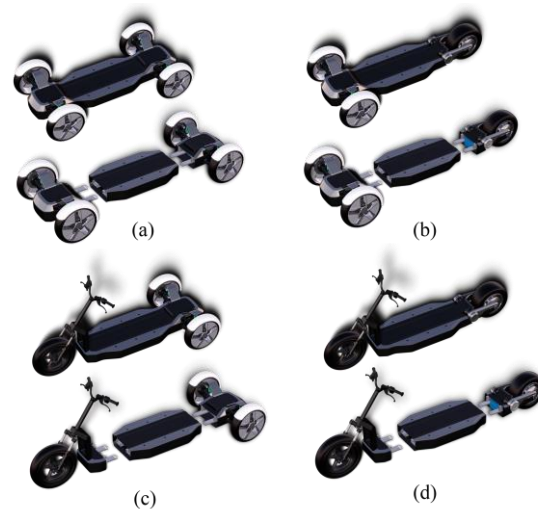

Figure 16: Variants of platform from modular design in horizontal direction: (a) four-wheeled, (b) three-wheeled tadpole, (c) three-wheeled delta, and (d) two-wheeled models

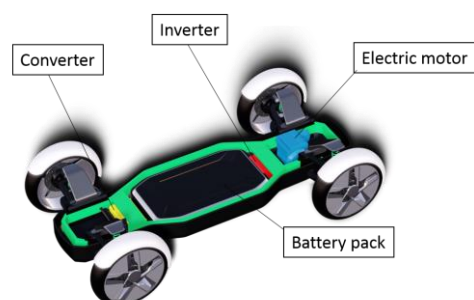

Figure 17: Package layout of major electric components in four-wheeled platform

Finally, Figure 18 shows a preliminary design for the interface between the front or rear sub-module and the middle sub-platform. This interface uses two tabs, shaped similar to those ‘tines’ of a fork lift, which are attached to the front and rear sub-modules and inserted into the slots of the middle sub-platform. This interface design is expected to



be effective in supporting high bending moments exerted by the static and dynamic loads of the vehicle while being driven on rough roads. Combining the vertical as well as horizontal modularity yields tens of variants, which will certainly satisfy a broad range of market needs. And, this will contribute to the alleviation of the economic challenge by serving many small segmented markets with these variants that may economically be developed and produced by sharing common components.

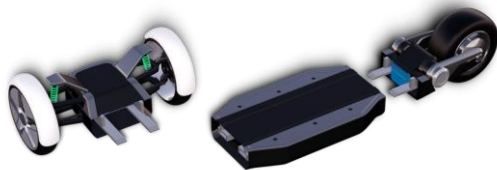

Figure 18: Preliminary design for interface between sub-modules and sub-platform

## 5 Conclusions

In order to address various socioeconomic challenges such as global climate changes, fast ageing society, and drastic urbanization, it seems to be the right time to change the century-long concept of automobile. Among a few candidates, electric personal mobility is expected to be one of the major mobility means that will emerge in the near future. Yet, the segmented market for each design of personal mobility is so small that no enterprise wants to heavily invest into such business.

This paper proposes the modular design strategy to address this problem. By conducting a preliminary design project, this paper has shown it possible to realize modular design at two levels (yielding body variants, and platform variants) and easily create tens of variants sharing common platforms. This will lead to less time to market for many variants and the economies of size. It was also demonstrated that the industrial designers and engineering designers must closely collaborate in steps of the design process adopted in this work, i.e. conception, ideation, development, refinement, and simulation steps. It can thus be concluded that the modular design strategy, if used extensively enough, will help enterprises resolve the economic barriers and launch a business of offering a broad range of personal mobility variants to the collectively big market. This will certainly enhance the chances that personal mobility will replace many of the present automobiles and thereby alleviate many of the socioeconomic problems facing the humankind.

## Acknowledgments

This work was supported by Hongik University Research Fund. Authors are grateful for the support.

## References

- [1] United Nations Department of Economic and Social Affairs, *World Urbanization Prospects: The 2014 Revision*, ST/ESA/SER.A/352, United Nations, New York, 2014.
- [2] United Nations Department of Economic and Social Affairs, *World Population Ageing 2013*, ST/ESA/SER.A/348, United Nations, New York, 2013.
- [3] M. Costes, *et al.*, *Modular Design of Automotive Platforms: An Innovation Approach to Reduce Cost, and Time to Market*, INOVEV, 2013.
- [4] EvaluateServe, *Platform Strategy will Shape Future of OEMs: Flexibility to Drive Growth*, White Paper, 2012.
- [5] O.L. de Weck, E.S. Suh, and D. Chang, *Product Family and Platform Portfolio Optimization*, DETC03/DAC-48721, Proceedings of 2003 ASME Design Engineering Technical Conferences, Chicago, U.S.A., September, 2003.
- [6] <http://www.psa-peugeot-citroen.com/en/automotive-innovation/innovation-by-psa/emp2-modular-platform>, accessed on 2015-01-06.
- [7] K. Ulrich and S. Eppinger, *The Product Design and Development*, McGraw-Hill, New York, Second edition, 1999.
- [8] K. Otto and K. Wood, *Product Design: Techniques in Reverse Engineering and New Product Development*, Chapters 8 and 9, Prentice Hall, New Jersey, 2001.
- [9] G. Pahl, *et al.*, *Engineering Design: A Systematic Approach*, Springer, 3<sup>rd</sup> ed., 2006.
- [10] <http://brochures.renault.co.uk/f07af789-35d0-46dc-9754-410d9d05e5e3/view>, accessed on 2014-10-09.
- [11] [http://www.toyota-global.com/innovation/personal\\_mobility/i-road/](http://www.toyota-global.com/innovation/personal_mobility/i-road/), accessed on 2014-10-09.
- [12] *Devices for Use in Defining and Measuring Vehicle Seating Accommodation*, SAE J826, July 1995.
- [13] *NX7.5 Help Library: General Packaging Help*, UGS Corporation, 2010.
- [14] S. Macey and R. Gilles, *H-Point: The Fundamentals of Car Design and Packaging*, Design Studio Press, 2009.

- [15] *CarSim User Manual*, Ver. 8, Mechanical Simulation Corporation, 2009.
- [16] *Laboratory Test Procedure for Dynamic Rollover: The Fishhook Maneuver Test Procedure*, New Car Assessment Program (NCAP), U.S. National Highway Traffic Safety Administration, March 2013.
- [17] T.D. Gillespie, *Fundamentals of Vehicle Dynamics*, SAE Inc., Washington, U.S.A., 1992.
- [18] A. Hac, T. Brown, and J. Martens, *Detection of Vehicle Rollover*, SAE Transaction, No. 2004-01-1757, 2004.

## Authors

Hyunjune Yim is Professor and Associate Director of Personal Mobility Research Center at Hongik University, Korea. Professor Yim got B.S. and M.S. from Seoul National University, Korea, and Ph.D. from M.I.T, USA, all in mechanical engineering. His current research interests are focused on design and development of various types of future personal mobility, particularly for the ageing society.



Keun Lee is Professor in Industrial Design, and Director of Personal Mobility Research Center, Hongik University, Korea. Keun obtained B.A. and M.A. from Hongik University, and M.A. from Royal College of Art, UK, all in vehicle design. Professor Lee's research activities have been and are industrial design of various products and services, with focus on electric vehicles and minimal mobility.

